

HAZARDS

TRANSPORTATION MODES

Marine

- Rolling, pitching, heaving, surging, swaying and yawing motions of ocean vessel.
- Wave impact (water shipping over the bow impacting on deck stowed cargo or containers during heavy weather).
- Navigation exposures: sinking, stranding and collisions.
- Temperature extremes resulting in heat or freeze damage.

Rail

- Acceleration and deceleration. • Coupling impact during car humping operations.
- Swaying on curves.
- Shock and vibrations.
- Derailments.

Air

- Changes in atmospheric pressure and temperature.
- Acceleration and deceleration forces.
- Turbulence.

Surface

- Braking and acceleration.
- Coupling action and impact against loading docks.
- Vehicular accidents (collisions, overturns).
- Shock and vibrations.
- Road and weather conditions.

Handling and Storage

- Rapid acceleration and deceleration during lifting and lowering.
- Improper forklift operations.
- Pushing and dragging cargo when inadequate material handling equipment or in-experienced labor is used.
- Weight of superimposed packages.
- Failure to keep stacks plumb.
- Long-term storage resulting in crushing of shipping package(s).

Water Damage

- Contact with rain, snow or sea water.
- Defective intermodal container, or ship-ping package.
- Condensation (ship/container or cargo sweat).
- Flooding (cargo stored on inadequately drained surface).

- Sprinkler discharge.

Theft and Pilferage Hazards

- Hijacking of entire container and cargo.
- Inadequate security measures at storage, staging or loading/discharge point.
- Misrouting or non-delivery of cargo due to insufficient marks.

Contamination

- Incompatible cargo stowed in the same hold or container.
- Infestation.
- Wildlife and rodents.
- Insects.
- Reptiles.

Fire

- Ignition caused by friction, spontaneous combustion, external heat and/or chemical sources.
- Smoke damage.

CAUSES OF LOSS

The figures in the following presentation, while based on our own loss experience, are of a sufficiently large volume of claims to be considered generally representative of the industry.

Approximately 80 percent of all cargo losses are preventable. The prudent shipper recognizes that efforts in properly preparing, packing and marking shipments have a great influence on successful delivery of goods.

Attention to the basic principles and techniques of export packing will help reduce the loss of cargo due to pilferage, minimize damage from improper handling/storage and protect against water damage.

Customer satisfaction and repeat orders are only two of the benefits that stem from a professional approach to cargo shipment. Reductions of time and money spent in tracing, locating and making adjustments on lost, damaged or pilfered goods contribute to a better bottom line.

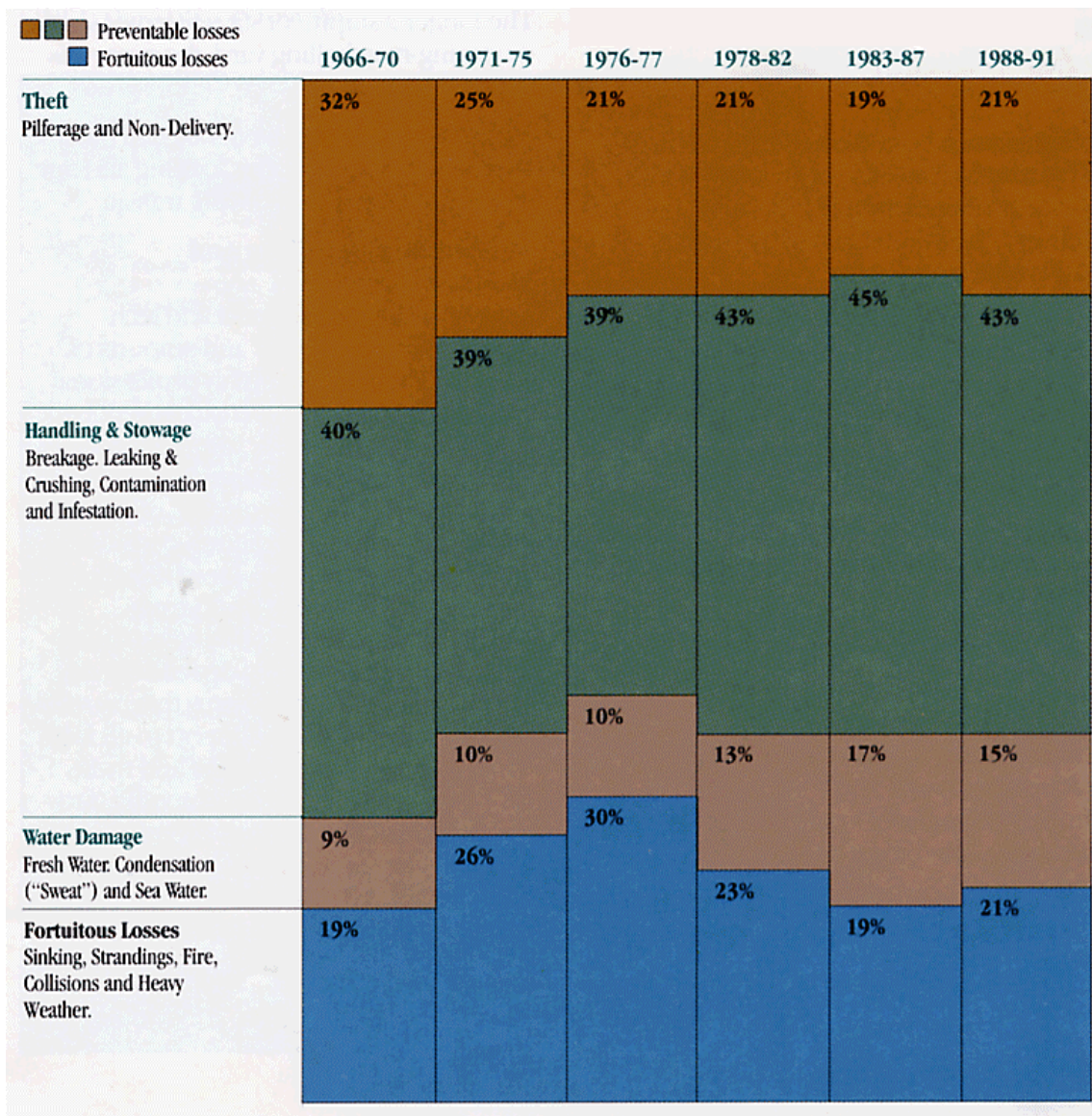

PREVENTABLE LOSSES

Another critical component of cargo loss control is carrier selection. Services and facilities available to the shipper should include adequate cargo protection, modern equipment, clean stowage and fair claims policy.

Facts that explain why cargo is lost or damaged in transit are the most vital ingredients in judging carrier performance. The following pages suggest positive actions, within a shipper's control, which can be taken to reduce preventable losses. Beyond these actions, selecting carriers based on their performance is a necessary step.

Minimizing Loss from Theft Group

With roughly one fifth of all preventable losses attributed to theft/pilferage/non-delivery, the following fundamental precautions seem in order:

- Use only new, well-constructed packing. Deterioration or collapse of flimsy or previously used fiberboard boxes, wood crates or bags during handling or transit invites pilferage through exposure of the contents.

- Use specifically patterned gummed sealing tapes, which enable quick detection of tampering.
- Use shrink-wrapping, strapping and banding.
- Use coded markings. Descriptive labeling, illustrations or prominent display of trademarks, logos, and corporate names simplify the pilferer's task. Enroute advertising provides little if any benefits.

NOTE: Codes should be changed frequently to avoid cargo handler's familiarity with them.

- Use bright color coding on sides and corners of items in the same shipment to facilitate identification thus minimizing the likelihood and extent of stray pieces.
- Unitizing of multiple or non-uniform parcels will keep your shipment together and discourage pilferage. This consolidation may include shrink wrap containerization, palletizing and/or banding.
- Losses should be reported immediately to your insurer, carrier(s), law enforcement agencies and other appropriate parties. Quick action can result in recovery.
- In addition to the foregoing physical security guidelines, the shipper should insist on prompt pick-up and delivery of cargo. The longer a shipment stays in a pier shed or staging-marshalling yard, the more it is exposed to loss.
- Containerized shipments should have the container sealed after loading and any subsequent openings during transit.

Minimizing Handling and Stowage Damage

Cargo handling equipment and techniques in the various air and seaports of the world range from highly professional to unskilled. The transit environment i.e., rough seas, turbulent air, sub-standard roads and uneven track sections, subject your cargo to every imaginable motion and impact. These conditions, considered alone or in conjunction, demand packing for the "toughest leg of the journey"

Proper selection of packing methods and material is primarily dependent on the nature of the cargo. Items that provide complete and uniform support to all faces of the package are the easiest and most economical to prepare for shipping. Articles that do not completely fill the selected package must be cushioned and/or blocked, braced, anchored or otherwise immobilized to prevent damage to the cargo.

Some Keys:

- Do not exceed the rated weight and volume capacity of the package and/or inter-modal container.
- Internal blocking and bracing should distribute the contents' weight over entire surfaces rather than concentrate on one or two critical points. The design and application of the materials should be compatible with the load to be supported and the size, shape and strength of the bearing areas.
- Cushioning designed to absorb the energy of shocks and vibrations caused by external forces should be selected on the basis of various factors such as shock resistance, fragility, size, weight, shape and surface finish of the cargo.
- Unitize, palletize or assemble cargo into the largest practical unit consistent with handling, weight and dimension limitations at transshipment point and destination. A unitized load of fiberboard boxes adequately wrapped, strapped and provided with a pallet or skid base will have

a much greater survival rate than fiberboard boxes that must be handled individually. Unitized cargo requires use of mechanical handling equipment, substantially reducing exposure to the inherently rougher manual techniques.

NOTE: The required equipment must be available at ports of call.

- Use cautionary markings and handling instructions in English and in the language of the country of destination. Inter-national pictorial symbols should also be used to provide universal handling information.
- Clear and complete shipping marks and instructions should appear on at least three (3) surfaces of the exterior package to avoid the rolling, tumbling and flipping of packages in the search for marks and delivery information.

Minimizing Water Damage

Rain, high humidity, condensation and sea water, separately or in combination, can reduce otherwise stable cargo into a ruin of soggy, stained, mildewed, rusted or de-labeled merchandise. Salt spray driving across the vessel deck, a rain-swept storage yard, an open truck, the insidious dripping of condensation from the interior of a ship's hold or container or sweat forming on the cargo itself are all common hazards.

Adequate preparation and packing can protect cargo from these hazards:

- Apply preservatives, corrosion inhibitors or waterproof wrapping directly to the item.
- Provide waterproof linings on the interior of outer packages. Use of desiccants (moisture absorbent materials) in conjunction with vapor proof barrier liners and wraps is particularly effective in protecting moisture sensitive items.
- Shield cargo on top and sides by use of waterproof shrouds. Place cargo on skids, pallets or dunnage thereby elevating the cargo above any poor drainage areas.
- Crates and other large containers should have drain holes in the bottom to preclude collection of water within the packing.
- Containerization does not guarantee protection against water damage. The potential for condensation and holed/leak^y containers exists.
NOTE: Indelible inks, paint and water repellent labels should be used to eliminate obliteration of marks, shipping instructions and handling symbols.

HOW TO FILE A CARGO CLAIM

If you are an exporter insuring your shipments under a Special Marine Policy, it's most likely that your overseas customer will be the first to become aware of a potential claim. There is a listing on the reverse side of the special marine policy explaining the steps one should take, including the names and addresses of claims settling agents in major ports of the world. If there are none nearby, the claimant is usually directed to contact the nearest correspondent of the Institute of Marine Underwriters or a Lloyd's agent.

If you are an importer, there are certain instructions to be given to those in your organization who receive or take delivery of your merchandise. It is most important that all packages be examined and counted before signing for the shipment. If there are any signs of potential loss or damage, such as breakage or wetting of the shipping package, or the number delivered does not match that shown on the bill of lading, an exception should be taken by noting the damage and/or shortage on the delivery document before accepting delivery.

If your merchandise is of a fragile or delicate nature subject to breakage, it is important that you unpack and check its condition as soon as possible even if there is no visible damage to the

packing. You may have what is known as concealed damage.

Once damage is discovered, there are three things you must do without delay:

1. Make every effort to reduce the loss and/or prevent further loss as provided under the Sue and Labor clause of most Open Cargo Policies. This could include rebagging, reconditioning and/or separating damaged cargo from sound. Reasonable expenses incurred in taking such steps are reimbursable in addition to any payment of the claim itself. The insured is expected to do exactly what he or she would do if the shipment were uninsured.

It is incumbent upon the insured to act as a prudent party in minimizing all damages.

2. Notify your agent or broker so that a survey of the damage can be arranged promptly. The carrier or the carrier's agent should be notified of the time and place of the survey so that they can be re-presented. If practical, the damaged cargo and the container(s) in which it was delivered should be retained in the condition received until after the survey unless further damage will result by so doing.

3. It is essential that a claim be made in writing against the carrier (air, inland or ocean) as soon as the loss is known (see sample letter). This can be in any form, but must include the bill of lading number, the name of the carrying vessel, a description of the loss or damage and a document stating that the carrier will be held responsible for the loss or damage.

The rates you are charged for cargo insurance are influenced in the ultimate by your experience (premiums versus losses). It is in your best interest to see that losses are reduced by putting the insurance company in a good position to take action against the carrier to recover all or at least a portion of the claims the company pays you. This is called subrogation and amounts recovered are credited to your account.

Once the survey has confirmed that loss or damage has occurred, and was caused by one of the insured perils, the following documents will be needed to substantiate your claim:

1. Whatever document was issued to substantiate the amount of insurance placed and the coverage provided. On an export shipment this would be the original and duplicate of the Special Marine Policy. For imports, it would probably be a copy of the declaration or bordereau.

2. Ocean (or Air) bill of lading-also transshipment bill of lading and railway freight note when applicable.

3. Original shipper's invoice.

4. Packing list, weight certificates or other evidence of the nature and condition of the goods at the time of shipment.

5. The survey report if an independent surveyor was called in to represent your interest. Also, include the annotated delivery document.

6. Copy of claim notice to the carrier and the carrier's reply when it is available. In special cases, other documents may be requested. A typical notice of a cargo claim could read as follows:

Some words of caution: the claims notification letter should have a demand for money and the amount should be the highest anticipated amount, usually the invoice value, as the claim can be amended when the actual extent of loss is determined. Never use phrases such as "more" / or less or estimate."

If all the preceding papers are included in the submission of your claim, it will certainly speed up the processing.

X 4 7

E X P O R T S
I M P O R T S

South Eastern Airlines
235 Central Avenue
Graham, PA 19692

6/30/92
Bill of Lading # : 004-86479002
Flight # : South Eastern Airlines #924
Shipment : Blender Components
Date Delivered : 6/30/92
Our Reference # : 16988

Gentlemen:

This is to advise you of loss and/or damage to
the above referenced shipment.

Consider this our claim in the amount of
\$2,556.64.

Complete documentation to follow.

Sincerely,



John Winters
President

cc: Insurer (Policy # P 102496)

2218 Lace Avenue
Philadelphia, PA 13019
215•555•7771

An ocean cargo notice would have a heading reflecting the voyage information and bill of lading number

Time Limitations

	<i>Via</i>			
	<i>Air Freight (Domestic)</i>	<i>Air Freight (International)</i>	<i>Domestic Regulated Land Carriers. Rail, Truck and Freight Forwarders</i>	<i>Ocean</i>
Loss, Damage or Delay	CHECK INDIVIDUAL CARRIERS' AIR WAYBILLS FOR DIFFERENT RULES— PARTICULARLY EXPRESS SERVICES	7 days from delivery if damaged. 14 days if delayed.	9 months from delivery.	1 year from delivery (check Bill of Lading for shorter time limits).
Concealed Damage	CHECK INDIVIDUAL CARRIERS' AIR WAYBILLS FOR DIFFERENT RULES— PARTICULARLY EXPRESS SERVICES	7 days from delivery.	If written notice is not given within 15 days of delivery, claimant has burden of proving they did not cause the damage.	Report in writing within 3 days of delivery.
Non- Delivery	CHECK INDIVIDUAL CARRIERS' AIR WAYBILLS FOR DIFFERENT RULES— PARTICULARLY EXPRESS SERVICES	120 days from date of issue of air waybill.	9 months after a "reasonable time" for delivery.	1 year from scheduled delivery.

Individual carriers may have specific requirements regarding claim notification and carrier's rules should be consulted. Also, all domestic (U.S.) deregulated land and air movements may be subject to individual contracts that can shorten the time limitations for notification of claim.

MARINE SERVICE

Through their diversified subsidiaries, CIGNA Companies offer worldwide claims settling facilities, Risk Management consulting services and recovery capabilities. Specific and descriptive information concerning marine insurance and related services can be obtained by writing:

INAMAR one of the ACE Group of Insurance & Reinsurance Companies
Two Liberty Place
1601 Chestnut Street
TL30A
Philadelphia, PA 19103

In addition, we maintain a staff of marine technical specialists strategically located in the major ports of the world. Experienced in packing, cargo handling and all modes of transport, they are dedicated to the prevention of losses.

TRANSPORTATION

Several modes/methods of transportation or refinements of previous ones need to be discussed. The following terms with definitions/explanations are designed to assist the shipper in understanding the current state-of-the-art, its evolution and perhaps future developments.

General Cargo Vessels

These vessels have cargo holds, tween decks and conventional weather deck hatch covers. They are designed to handle a multitude of break-bulk cargo e.g., pallet loads, bags, drums, cartons, cases and crates. Additionally, containers can be accommodated on deck and sometimes under deck. In some instances, deep tanks for cargo oils may be fitted in holds. These carriers have their own cargo cranes; therefore, cargo is generally loaded aboard using vessel's gear and forklift machines. Although this is the traditional method of ocean cargo carriage there is a growing trend toward container or Ro-Ro type vessels due to the labor intensity of general cargo handling.

Container Vessels

This vessel category carries all of its cargo in unitized containers both on and under deck. The latter are stowed in vertical cells formed by angle corner guides. The deck-stowed containers are stacked sometimes five or six high and twelve across, inter-locked with fittings and secured by special lashings. Most of the container vessels are not equipped with cargo handling gear, relying instead on shore cranes. Nonetheless, containers do enjoy rapid loading and discharge. Some vessels are equipped with a plug-in system for refrigerated containers or have entire holds/cells under refrigeration.

Roll-On/Roll-Off(Ro-Ro)

This shipping system involves the direct driving-on and driving-off of cargo. The Ro-Ro method enables shippers to load cargo on the chassis, trailer and "low-boy" at the plant or warehouse site, transport the vehicles to embarkation points and have them loaded directly onto the vessel.

By rolling cargo on board these vessels and rolling it off at its destination, shippers can reduce the number of times their cargo is handled.

The inherent disadvantage of Ro-Ro is the waste of cargo carrying capacity due to undercarriage and all-around clearance requirements.

Although the degree of packing may be reduced for Ro-Ro shipments, keep in mind that the cargo will travel aboard an oceangoing vessel and will be subjected to all the hazards of an ocean voyage.

Variations on the Ro-Ro Theme:

Sto-Ro (Stowable Ro-Ro) -- Contrary to the Ro-Ro, no cargo remains on wheels but is directly loaded onto vessel decks. The stowage is similar to an open Load-on/Load-off (Lo-Lo) vessel; however, the cargo is brought on board either over a stern/bow quarter ramp or through a side port door. Vessel operations can turn to this concept of cargo handling as a means of combining the undoubted handling advantages of the Ro-Ro (improved turnaround times) with the efficiency of a Lo-Lo (increased utilization of a ship's cubic capacity).

Float-On/Float-Off-- A heavy deck semi-submersible vessel designed to permit oversized indivisible cargo being floated into position for deck stowage. The reverse procedure is used at the destination port where the load is floated from the submerged deck that is ballasted down for the outturn. The vessel travels with its deck and load above the water.

Trot-On/Trot-Off-- Ro-Ro conversion or version in which vessel trailer decks are transformed into modern cattle pens capable of accommodating in excess of 2,000 animals. New installations include provision of fresh water through evaporation and increased tankage "barns" for 1,600 cubic meters of hay or straw and an air circulation plant.

Combination Container and Ro-Ro Vessels -- This design allows for flexibility of operation by incorporating container and other wheeled cargo handling capability. These vessels carry containers on and under deck forward and have a stern ramp with tween decks for the carriage of Roll-on/Roll-off cargo in the aft underdeck area. The Ro-Ro cargo may consist of over-sized

pieces such as construction equipment, i.e., bulldozers and excavators, which are driven onto the vessel via the ramp. Containers can also be stowed on the Ro-Ro decks but are brought aboard on chassis and removed with forklift machines. If space and equipment is available the container can be left on its chassis during transport.

Heavy Lift Vessels-- Specifically de-signed to carry heavy or oversized cargo, these vessels meet the rising demand for block or modular transportation for fully assembled plants and/or equipment. Most of the heavy lift ships are self-sustaining diversified cargo handlers. They can be equipped with gantry or telescopic auxiliary cranes for the conventional load-on/ load-off ramps for Ro-Ro movements, and have semi-submersible capabilities to accommodate float-on/float-off operations. In some instances operators extend their activities to cover inland transit with multi-wheeled self-propelling transporters enabling carriage of cargo from the point of manufacture to final destination.

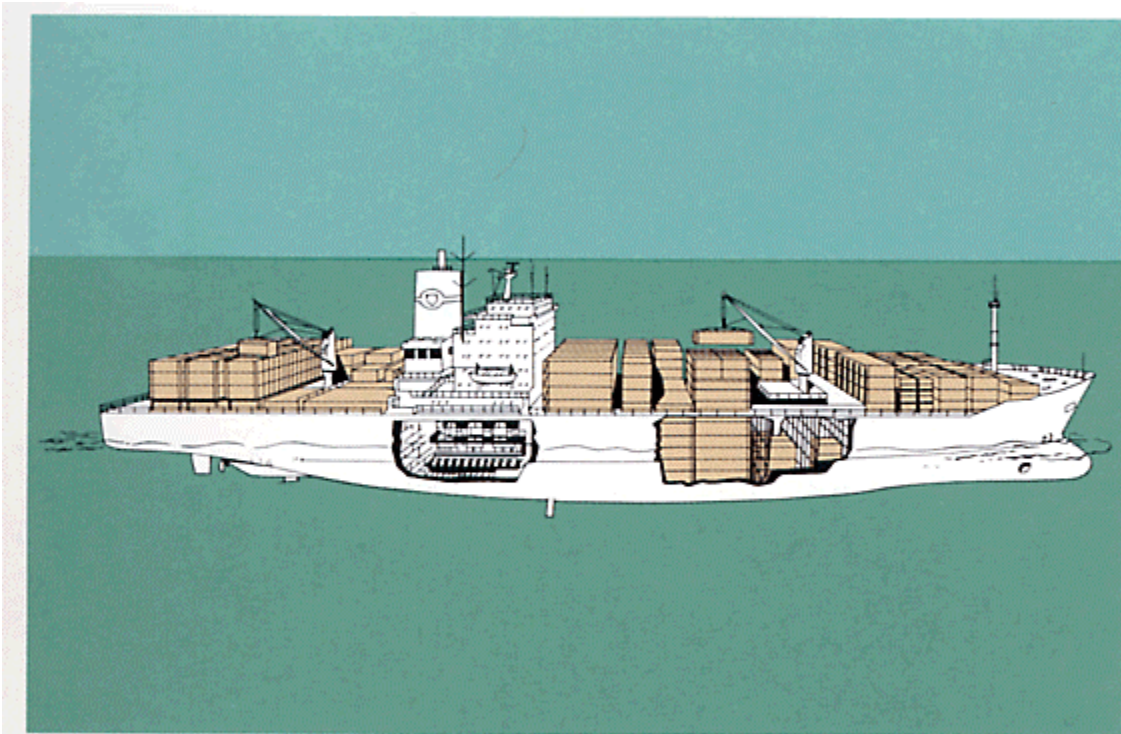

Container Vessel

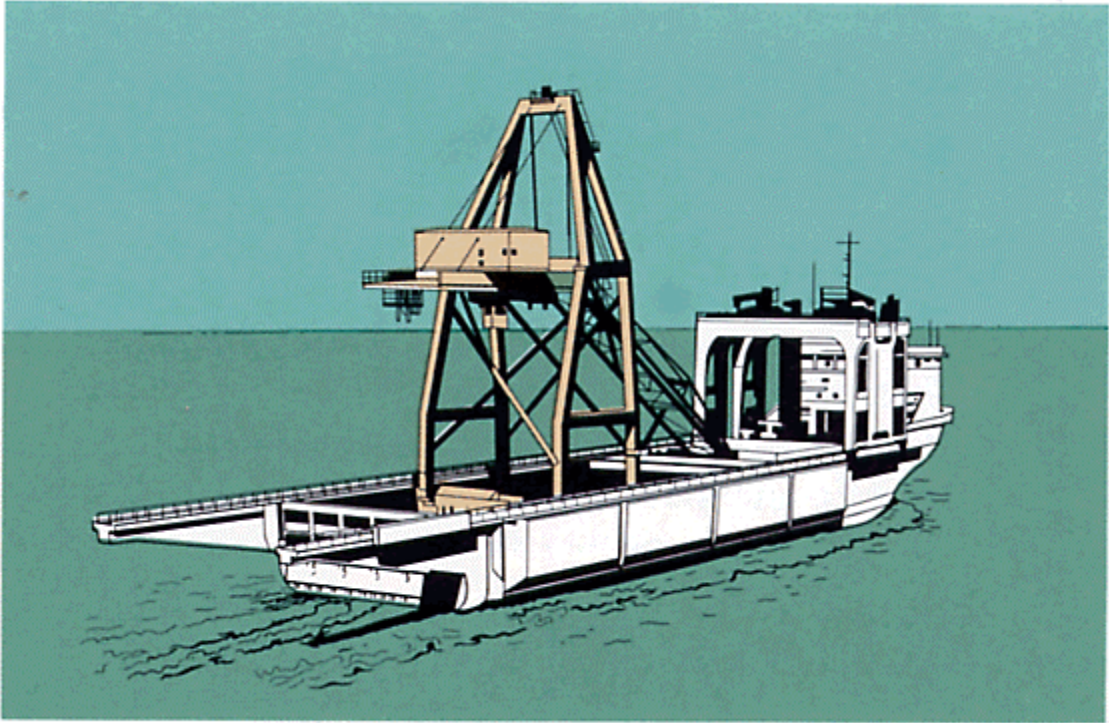

Heavy Lift Vessel

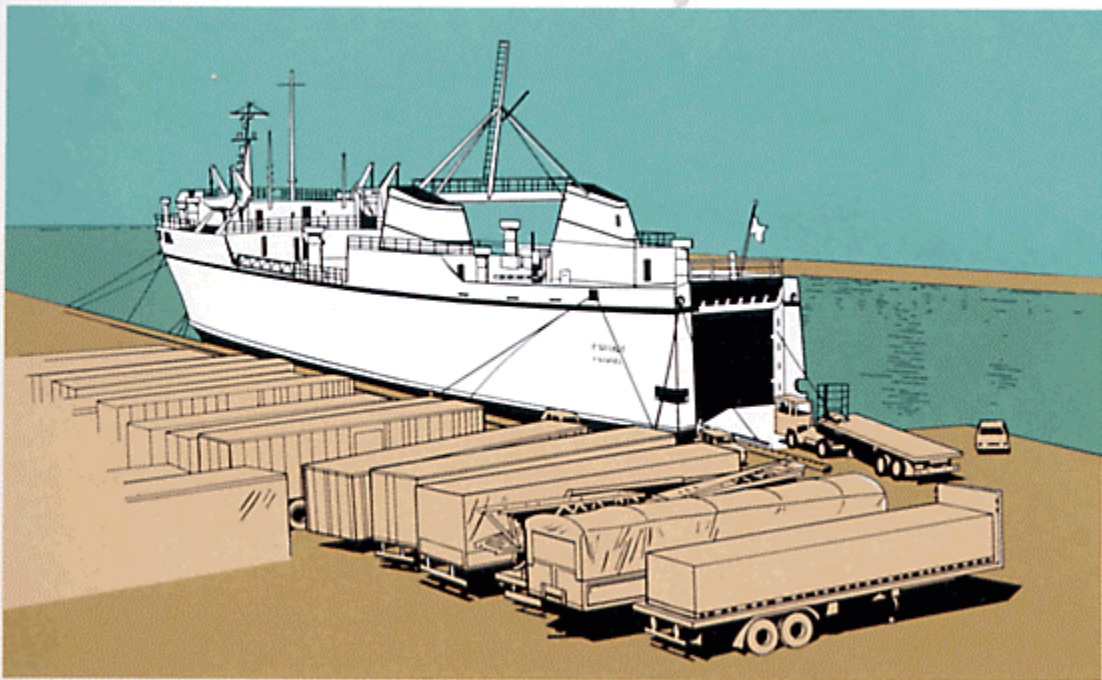

Ro-Ro Vessel

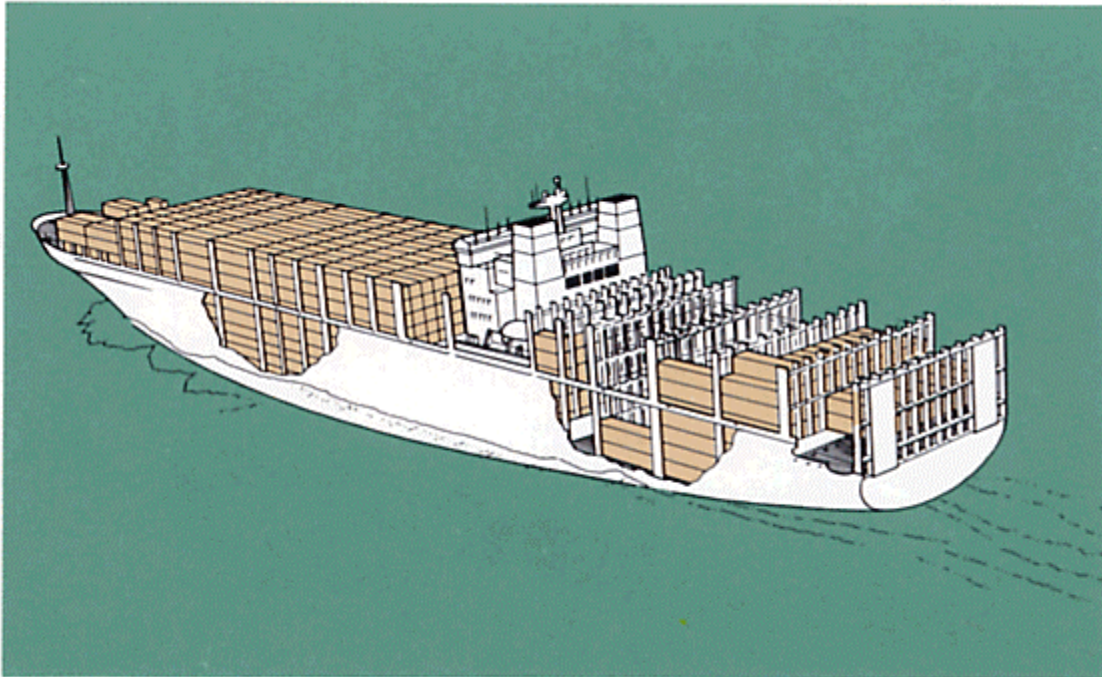

Hatchless Container Vessel

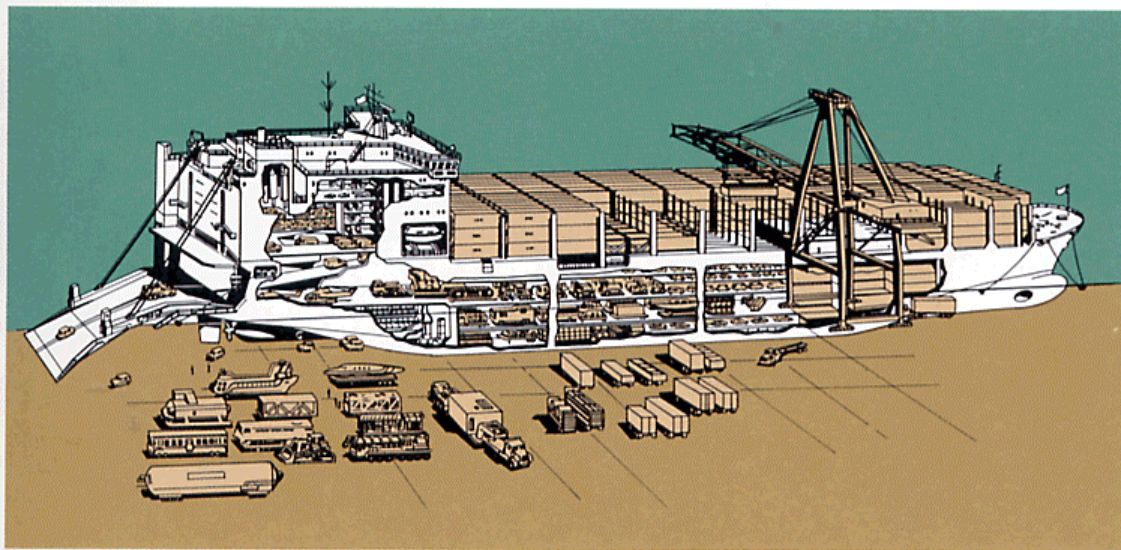

Combination Container/Ro-Ro Vessel

These ships are of a revolutionary design, answering the question “who needs hatchcovers?” In all but the two forward holds, reserved for special and non-containerized cargo, traditional hatchcovers are missing. Instead, permanent cell guides run from the tank top to several levels above deck. As a result of the continuous cells, container twistlocks and lashings are not used. Speed of load/discharge is improved and container shifting is reduced. Taking into consideration that five cargo holds are exposed to rain and sea water, emphasis has been put on the development of the most efficient bilge system.

The following is a copy of the Aircraft Capacities and Dimensions image... In the original document it was wider than a printable space. I narrowed the open areas to accommodate the whole image without changing the layout.

CONTAINERIZED CARGO

LOSS CONTROL—CONTAINERIZED CARGO

The use of intermodal containers for the transport of a great variety of cargo has become increasingly popular in recent years. Intermodalism – a concept that embraces the movement and transfer of standardized cargo containers by sea, air and surface has greatly reduced cargo handling, particularly in Door-to-Door shipments. Development of specialized containers with a wide range of types, sizes and configurations permits containerization of most cargo.

Prompt, undamaged arrival of the complete shipment at destination is the primary objective of the shipper. In committing goods to containerized transport, the shipper can reduce losses by:

- Select the proper container service.
- Selecting the right type of container for the goods in question.
- Inspecting the container to ensure proper accommodation and protection of goods.
- Packaging goods to withstand the hazards of the “toughest leg of the journey.”
- Stowing and securing goods in the container to prevent damage to the goods, container and transport vehicle.
- Properly describing and documenting the container contents, locking and sealing the container and recording container and seal numbers on all shipping documents.
- Timely unloading at destination.

INTERMODAL VARIATIONS

The popular intermodal container, adapt-able to carriage by truck chassis, railcar, barge and oceangoing vessel, is the most common form of containerization. The considerations governing preparation and stowage of the cargo in these containers are no less applicable to other methods of cargo transport.

Trailer-on-Flatcar (TOFC)— "Piggy-backing" highway trailers on container chassis that can be carried on specially equipped rail flatcars.

Container-on-a-Flatcar (COFC) — A carriage of intermodal containers detached from their highway chassis and "boggie" on rail flatcars.

Two recent developments in the rail movement of containers/trailers on flat cars have been introduced into the domestic (U.S.) market.

Double Stack Train —This service involves a series of containers/trailers, stacked 2 high on specially designed rail cars. Linking the major trading corridors, this system is designed to provide smoother rides than their surface competition, either truck, conventional flatcar or alternative rail equipment. In addition, a number of technical features enable high-speed transit with a minimum of shock and vibration to cargo through the dampening of slack, sway and vertical acceleration forces. To date, this method of transportation has demonstrated substantial reduction of damage and increased efficiency.

Trailer-Rail—This new piggyback system will allow railroads to handle the full range of

increasing diversity of trailer lengths over shorter hauls. The full system is composed of the following 3 components.

- The Trailer-Rail terminal, a bare-bones rail yard consisting of a track, parking area, driveway and ramp for handling the trailer on and off the railcars.
- The Tractor-Railer, a lightweight highway tractor, equipped with retractable steel railroad wheels that can both load and un-load trailers in the rail yard and pull a Trailer-Railer and train on the rails.
- The Trailer-Railer, the central part of the system, a short, four-wheeled car of skeletal design, with a drop deck platform that connects the front end of one trailer and the rear of another.

The entire loading cycle involves a tractor trailer driver backing a trailer into the drop deck of the railcar, "jackknifing" the trailer parallel with the track and positioning the trailer landing gear adjacent to a loading stanchion located at the side of the track. This stanchion is manually rotated across the track beneath the trailer landing pads. The driver then activates the hydraulic lift wheel of the tractor to lower the trailer until the landing gear rests on the stanchion. The next rail car is now able to be rolled into place.

Containerization and double stacking have led to increased use of land-bridging, i.e., ocean shipments from the Far East to West Coast ports and then trans-ported the cargo to inland markets via rail or truck. In Europe this concept is termed Microbridge or IPI (Interior Point Intermodal).

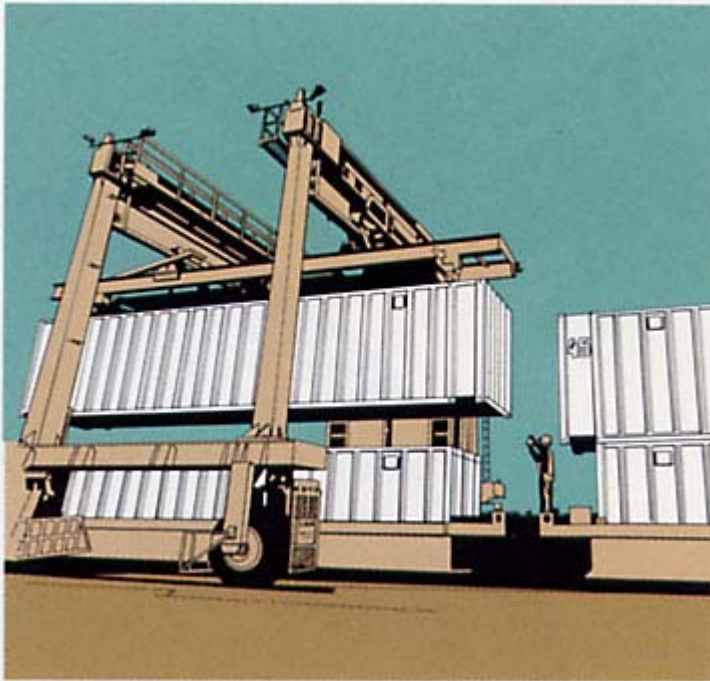

Double Stack Trains

SEA-AIR

The growing practice of routing cargo by both sea and air within a single journey has been somewhat obscured by the Double-Stack and other land-bridge developments. No longer stymied by incompatible equipment and scheduling, the ocean to air transshipment is now able to marry the low cost of ocean shipping with the timely convenience of air freight. Examples of this trade pattern include a sea-air leg originating in Japan and moving to North America's West Coast via ship. From there cargo is transferred to air freighter or combination passenger-cargo plane for the flight to Europe.

Other routes involving traffic to/ through South America and the Middle East have also been active. One of the problems inherent in this transportation hybrid is the increased exposure

to loss and damage during cargo transfer between the two modes. Some shippers have resorted to shipping loaded air cargo containers inside 20- and 40-foot long intermodal units for the sea transit.

Air Cargo Containerization — The unique aspects of cargo carriage via air and the application of Containerization to this transport mode are treated separately in this booklet. (See Air Cargo discussion.)

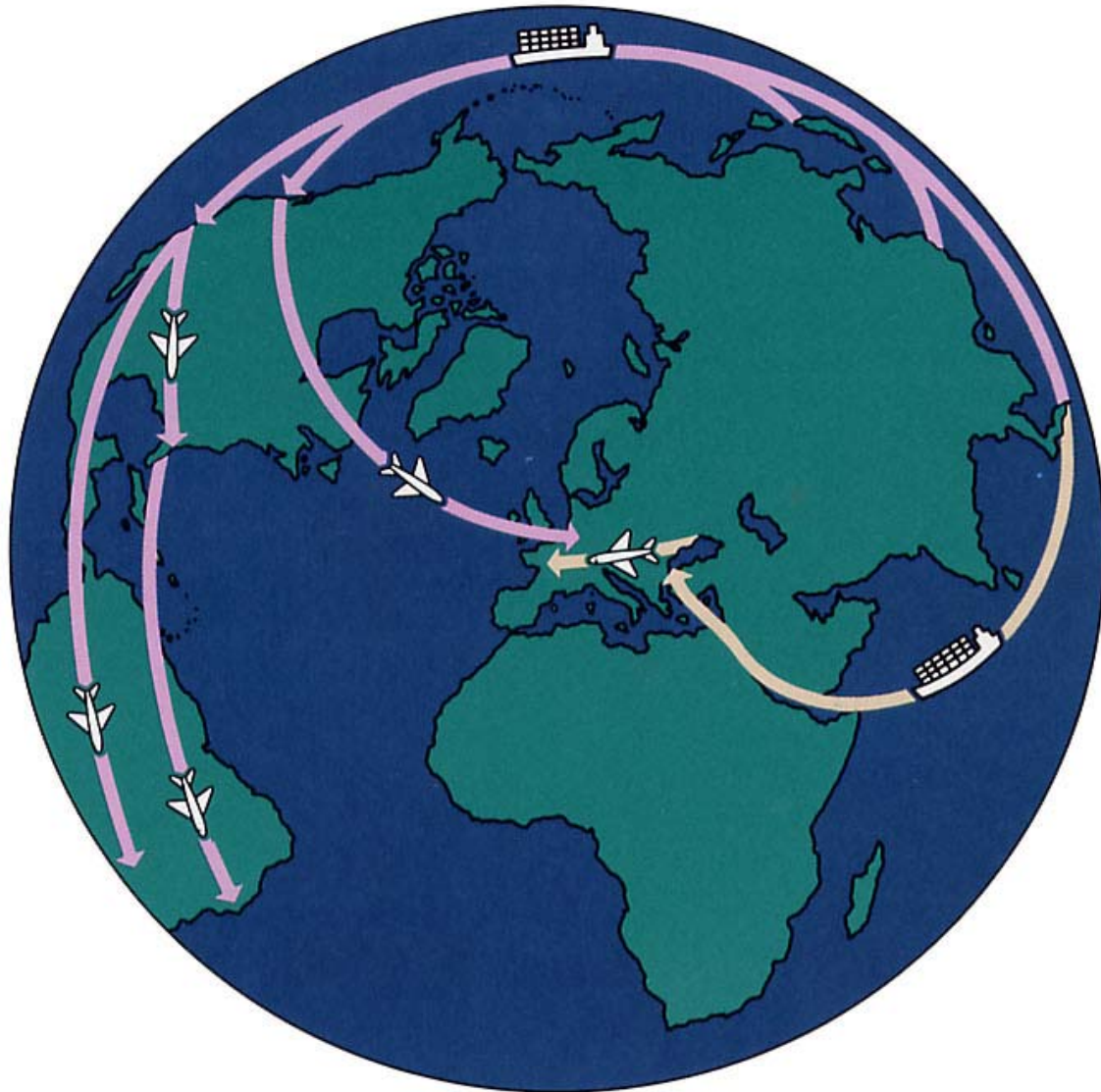

Sea-Air Routes

CONTAINERSERVICES

Door-to-Door (House-to-House)— The greatest benefits of Containerization are realized when the shipper uses the container to carry goods directly from his or her premises to his or her customer's location. Perhaps the only time the container will be opened while enroute is for Customers inspection. Reduced susceptibility to pilferage and theft, elimination of multiple handling of individual items of cargo and the least possible exposure to the elements are all attractive features of Door-to-Door service. In utilizing this type of service, the shipper accepts the additional responsibility of ensuring that cargo is properly stowed and secured in the container,

precluding damage to the cargo, container or transport vehicle.

The tendency to reduce packing protection of cargo destined for Door-to-Door container shipment must be resisted. The ocean leg of the voyage will still subject the cargo to severe motion stresses, considerably greater in force than during highway or rail movement. Reduction of packing protection must be carefully evaluated and implemented only after due consideration of the hazards of ocean transport, including the lifting force at transshipment points.

Port-to-Port (Pier-to-Pier) —When cargo volume does not provide for a full container load (less than container load or LCL) or when the shipper or consignee does not have the facilities to load or un-load the containerized cargo at his premises, he or she can utilize the services of forwarders, consolidators or the carrier to stow the goods in containers at the port of departure. This service is less attractive than Door-to-Door service. Since the cargo is not in a container for the entire journey, it is subject to the same degree of exposure to weather, handling and stow-age damage and theft/pilferage as break-bulk cargo. **MAXIMUM EXPORT PACKING STANDARDS ARE REQUIRED WHEN SHIPPING PORT-TO-PORT,**

Door-to-Port— Combinations of Door-to-Door and Port-to-Port service are possible, depending on the desires of the shipper and the facilities available. While these combinations are more advantageous than Port-to-Port service, the cargo will still be exposed to the hazards of theft, weather and additional handling during part of the journey.

AS IN PORT-TO-PORT SERVICE, THE CARGO MUST BE PACKED TO THE HIGHEST EXPORT STANDARDS.

LCL (Less Than Container Load) — On LCL shipments, the shipper can still load goods into a container, but the container will be delivered to a consolidation point at the pier where other shippers' goods will also be stowed in the container. What this means is that the smaller, low-volume exporter can still have cargo containerized, although this is not as desirable as a sealed House-to-House container.

SELECTING THE RIGHT CONTAINER

Consultation with the carrier will permit selection of the type and size container most suitable for the cargo.

Many types and sizes are available to the shipper. The most common is the dry cargo container that may be used for a great variety of general cargo. Specialized containers should be used for goods or commodities requiring special environments.

Particular attention must be given to the container weight limitations so as not to overload.

Cargo Containers

1. End Loading, Fully Enclosed— The basic intermodal container with end doors, suitable for general cargo not requiring environmental control while enroute.

2. Side Loading, Fully Enclosed— Equipped with side doors for use in stowing and discharge of cargo where it is not practical to use end doors, as when the container must remain on a railcar while cargo is placed in or removed from the container.

3. Open Top—Used for carriage of heavy, bulky or awkward items where loading or discharge of the cargo through end or side doors is not practical. Most open top containers are equipped with fabric covers and are often termed "soft" or "rag" top containers. Some open top versions are fitted with removable hatch-type panel covers or detachable full metal roof.

4. Ventilated—Equipped with ventilating ports on ends or sides, and used for heat generating cargo or cargo requiring protection from condensation (sweat) damage. Versions with powered air-circulating fans are available. Vents are normally fitted with baffles to prevent entry of sea or rain water.

5. Insulated—For cargo that should not be exposed to rapid or sudden temperature changes. Available in ventilated or non-ventilated versions. Some carriers provide containers with heating systems for special applications.

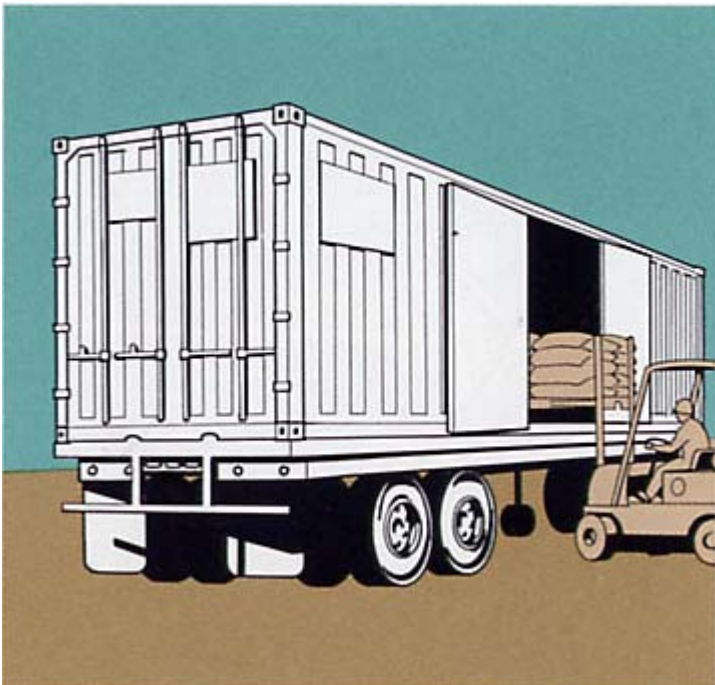
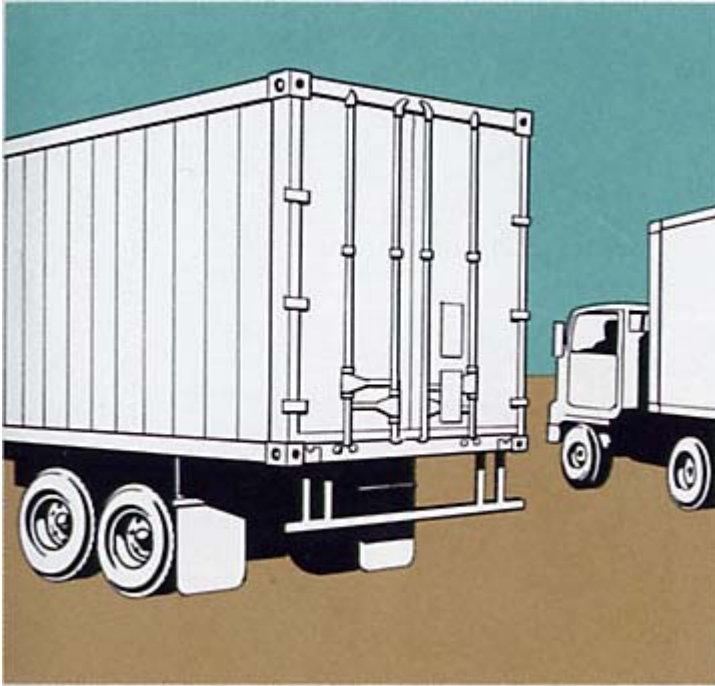

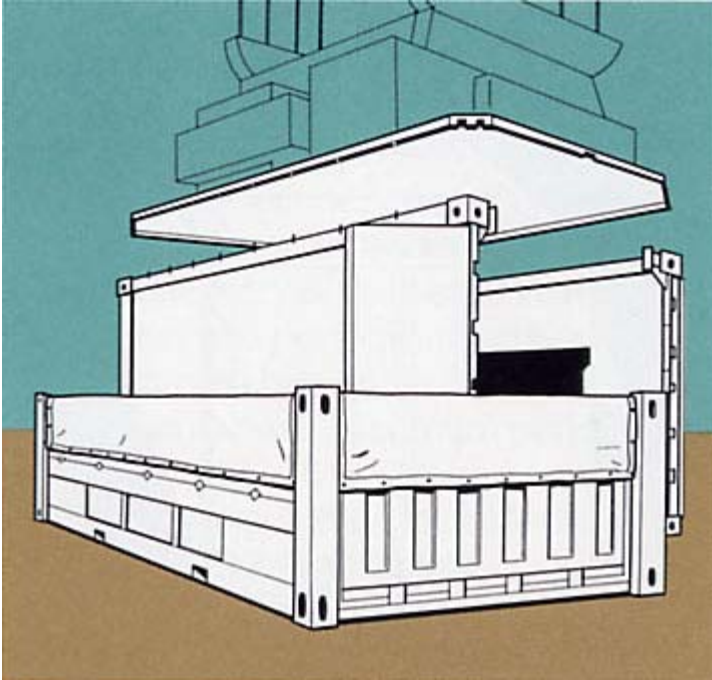

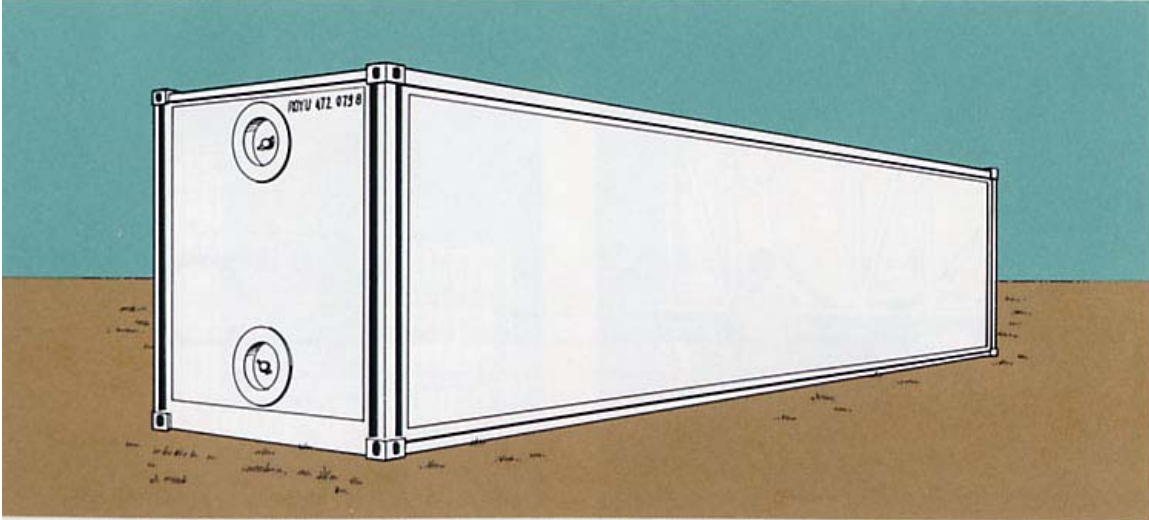

6. Refrigerated—Insulated and equipped with a built-in refrigeration system, powered by direct electrical connection or by diesel or gasoline generator. It is used primarily for foods or other commodities requiring a temperature controlled environment.

7. Liquid Bulk—Tank-type containers for carriage of liquids. Some have been designed to high level specifications for carriage of certain hazardous materials.

8. Dry Bulk—Designed for carriage of bulk cargo such as dry chemicals and grains.

9. Flat Rack—Available in a variety of sizes and models, the flat racks are used for lumber, mill products, large, heavy, bulky items, machinery and vehicles. Some are equipped with removable sides.

10. Auto — Used for carriage of vehicles and available in enclosed or open versions.

11. Livestock — Configured for the nature of livestock carried; containers are available for transporting poultry, cattle and other livestock. Also, transport boxes can be loaded onto flats.

12. Controlled Atmosphere—These systems carry a cylinder of liquid nitrogen and carbon dioxide. Through computer-based controls, the atmosphere within the container can be maintained at preset levels to meet requirements of commodity carried. Used mainly in the transport of produce to extend the post-harvest and storage life.

13. High Cube—These containers are used for high volume/low weight cargo and can greatly increase the cubic area available for cargo stowage. High cube containers are in heights to 9.5 feet and to lengths of a maximum of 48 feet.

14. Garment—With special tie downs and internal ceiling fittings, this container can handle hanging garments.

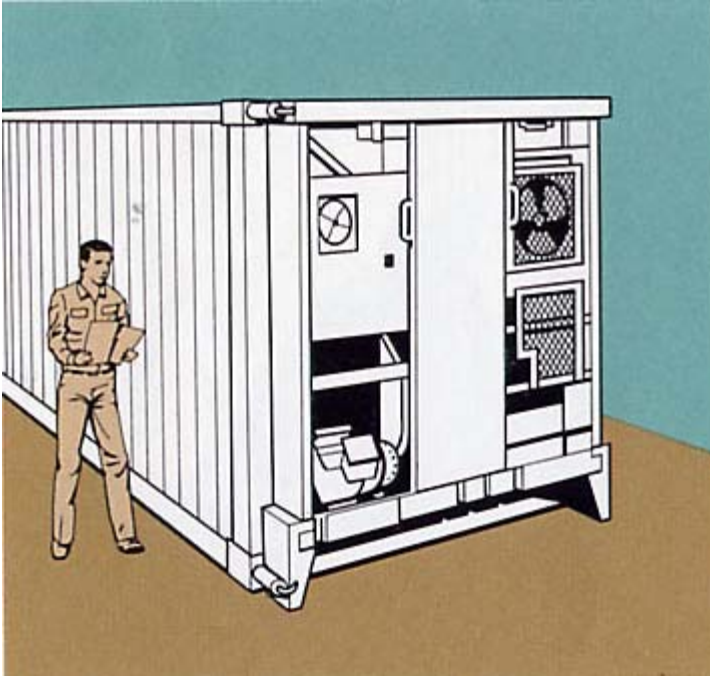

Refrigerated

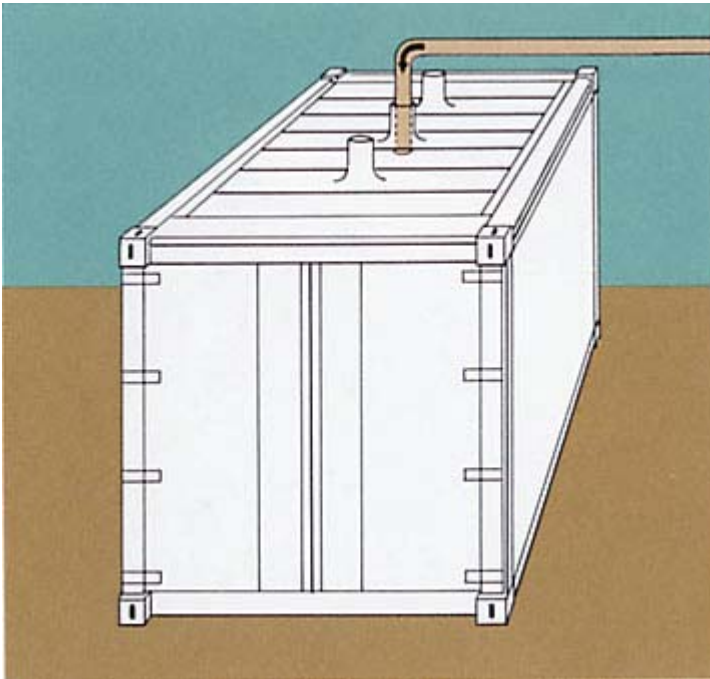

Dry Bulk

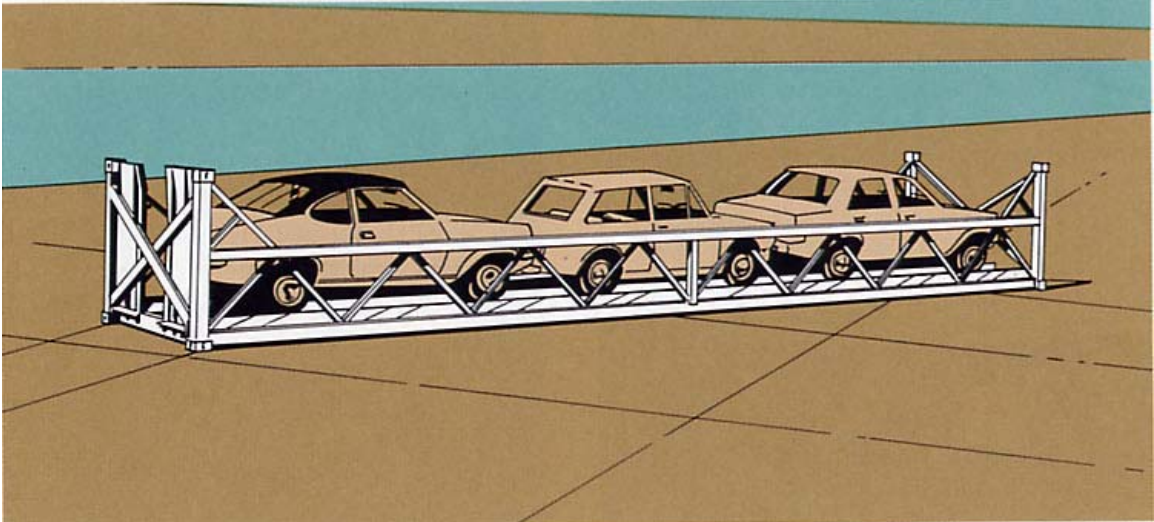

Auto

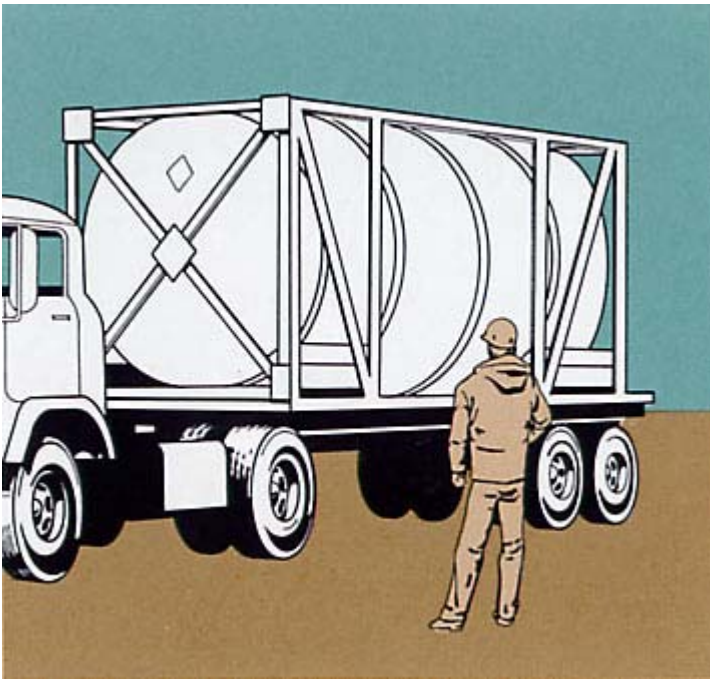

Liquid Bulk

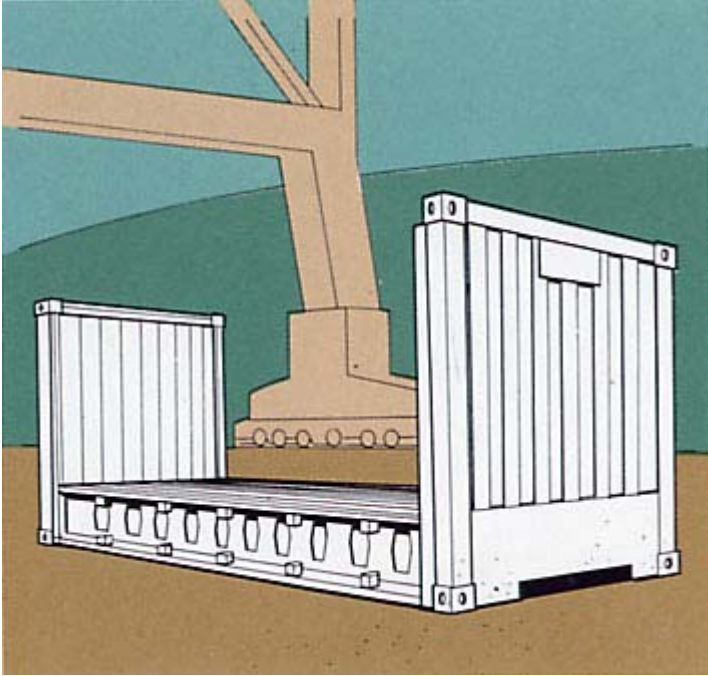

Flat Rack

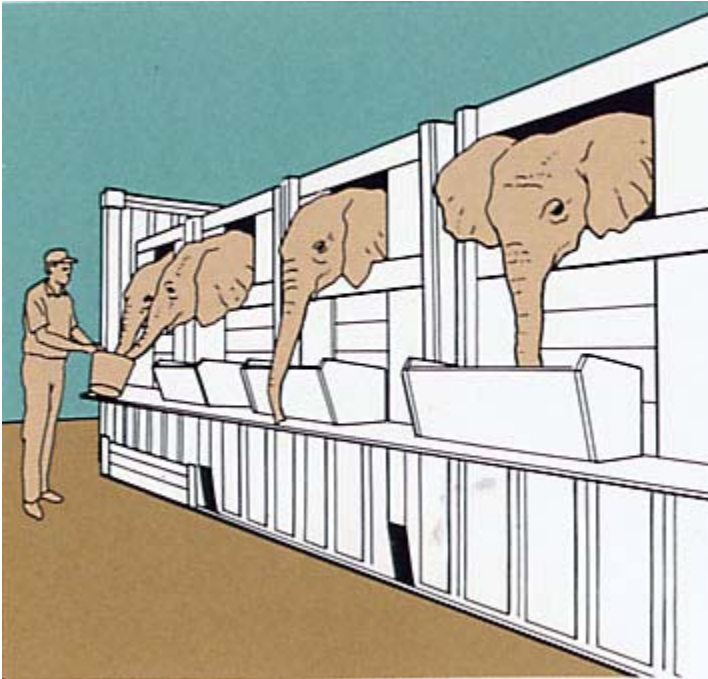

Livestock

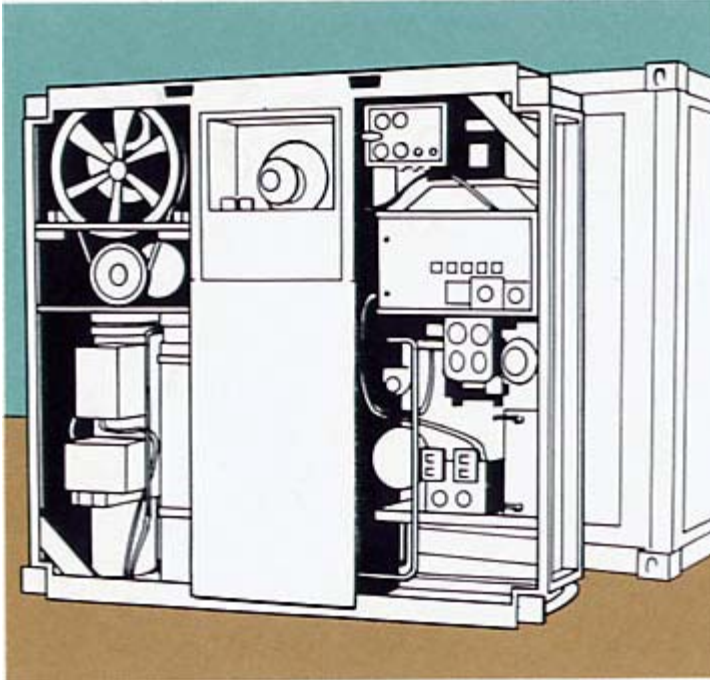

Controlled Atmosphere

CERTIFICATION OF INTERMODAL CONTAINERS

The International Convention for Safe Containers (ICSC), effective September 6, 1977, made certain structural requirements mandatory for containers moving in international trade. Under the Convention, approved units are issued safety plates that are affixed to the container at the time of manufacture. In addition, ACEP (Approved Continuous Examination Programs) or periodic examinations of containers in accordance with procedures prescribed or approved by signatory governments are required.

The owner or operator must maintain the container in safe condition.

A number of independent firms provide testing and inspection services for intermodal container operators. Certification of adequacy of construction occurs prior to delivery of the new container to the carrier and periodic inspections must be performed beginning five (5) years after manufacture. Maximum periodic examination interval is 30 months.

The shipper should look for the safety plate and ACEP or examination decal to determine that the container(s) supplied for his use have met adequate construction and maintenance standards.

Presence of the safety plate and examination decal is not, however, a guarantee that the container is presently free from defects, as damage may have occurred since the last certification inspection.

The shipper must take a personal inspection of the container before use to be absolutely certain that it is in condition to adequately protect his goods.

An understanding of the hazards to which a container may be exposed (as depicted in the two illustrations on pg 69) is essential. This knowledge will permit intelligent inspection of the container and also provide the background necessary for adequate preparation and stowage of the cargo.

INSPECTING THE INTERMODAL CONTAINER

With the advent of Containerization, it was anticipated that cargo damages would be greatly reduced. This has been realized; however, it is largely dependent upon the structural integrity of the container.

The following checklist will assist you in inspecting me container to be sure it will properly protect your cargo. Containers that leak or have inherent defects that endanger the cargo or pose a safety hazard to personnel must be rejected.

The interior must be free from splinters, snags, dents or bulges. These may interfere with loading. Serious defects indicate the container is structurally unsound.

- **Watertight Integrity**—"Light" tests whereby you enter the container, have the doors closed and look for light entry via the roof, side and door panels and deck are a must. Also, previous patches and re-pairs must be checked to ensure they are watertight. Hose (water) or smoke tests are alternative methods of discovery.

- **Fittings**—Cargo tie-down cleats or rings should be in good condition and well anchored. If ventilation openings are present, be sure that they have not been blocked off, and that they are equipped with baffles to prevent rain or sea water entry.

- **Cleanliness**— Free of residue from previous cargo particularly odors that may taint your goods. Also, check the container for nails or protruding fastenings that might puncture cargo package or inflatable dunnage.

The exterior must be free from dents, bulges or other damages; all may interfere with handling.

- **Doors**—Be sure doors can be securely locked and sealed: Check that door gaskets are in good condition and watertight when closed. Inspect door hardware closely If bolts or nuts can be easily removed from the outside with simple tools, it means that the container can be opened without breaking the seal or lock—an attractive invitation to the pilferer.

- **Fittings**—A quick look at the lifting fittings at each corner of the container will reveal those that are obviously damaged or unsafe. Check the fittings that secure the container to the trailer chassis; they should all be in working order and in use.

- **Covers/Hatch Panels**—If an open-top container, be sure that the fabric cover supplied with the container is in good condition and can be properly secured. Check hatch panels for close watertight fit.

The following is a partial checklist of typical types of damage.

Front

Front Panel—Dented, torn, holed or punctured.

Patches—Loose, not of same material as panel, not sealed or riveted with waterproof Customs-approved rivets, poor welds, not primed or painted.

Top Rail—Bent, cut, crushed or fractured.

Corner Posts—Bent, broken, cut, gashed or distorted.

Upper and Lower Corner Fittings and Attachments—Fractured or distorted fitting, cracked attachment welds.

Rivets—Loose or missing.

Welds—Improperly made, not primed or painted.

Sides

Panels—Dented, torn, holed or punctured.

Corner Posts—Bent, broken, cut, gashed or distorted.

Upper and Lower Corner Fittings and Attachments—Fractured or distorted fittings, cracked attachment welds.

Door Holdbacks—Damaged or missing.

Rear

Doors—Difficulty in opening and/or closing.

Door Panels (Metal or other)— Torn, cut, holed or punctured.

Door Locking Bars (Rods)— Seized, bent, broken or twisted.

Door Locking Bar Cams—Bent or broken.

Door Handle and Retainers— Broken, bent or missing.

Door Cam Lock Retainers (Keepers)— Bent or broken.

Door Hinges—Broken, torn, twisted, binding or seized.

Door Seals (Gasket and attachments)— Cut, torn or loose.

Door Header—Cut, broken, distorted or dented.

Door Sill—Cut, fractured or distorted.

Anti-Rack Device (if any)—Bent, cut, damaged or broken.

Rain Gutter—Bent, broken or crushed.

Roof

Panel—Punctured, dented or distorted.

Upper Corner Fittings and Attachments—Fractured or distorted fittings, cracked attachment welds.

Corner Protection Plate (where provided)—Punctured, dented or distorted.

Under Structure

Cross Members and Attachments— Crushed, cut, bent, distorted or broken loose from bottom side rails or floor.

Tunnel Recess (if any)—Cut, dented, distorted or cracked weld attachments.

Forklift Pockets (if any)—Cut, dented, distorted, bottom straps broken or bent.

Interior

Roof Sheet—Punctured, dented or distorted.

Roof Bows (if any)—Bent, cut or broken loose from roof.

Floor—Torn, gouged, broken, shrunken, warped, stained excessively.

Sides—Dented, torn, holed or punctured.

Logistic Track (side walls or floor)— Torn, loose, bent, missing or cracked welds.

Liners (where provided)—Torn, punctured, gouged, pulled loose, stained excessively.

Chassis

Tires—Proper inflation, adequate tread depth, damages such as cuts, breaks or separated recap.

Twist Locks—Twist lock and lock handles are in good operating order.

Landing Gear—Check the pads, crank, crank handle and braces for defective areas.

Lights and Reflectors—Check for proper working order.

Frame—Look for structural damages.

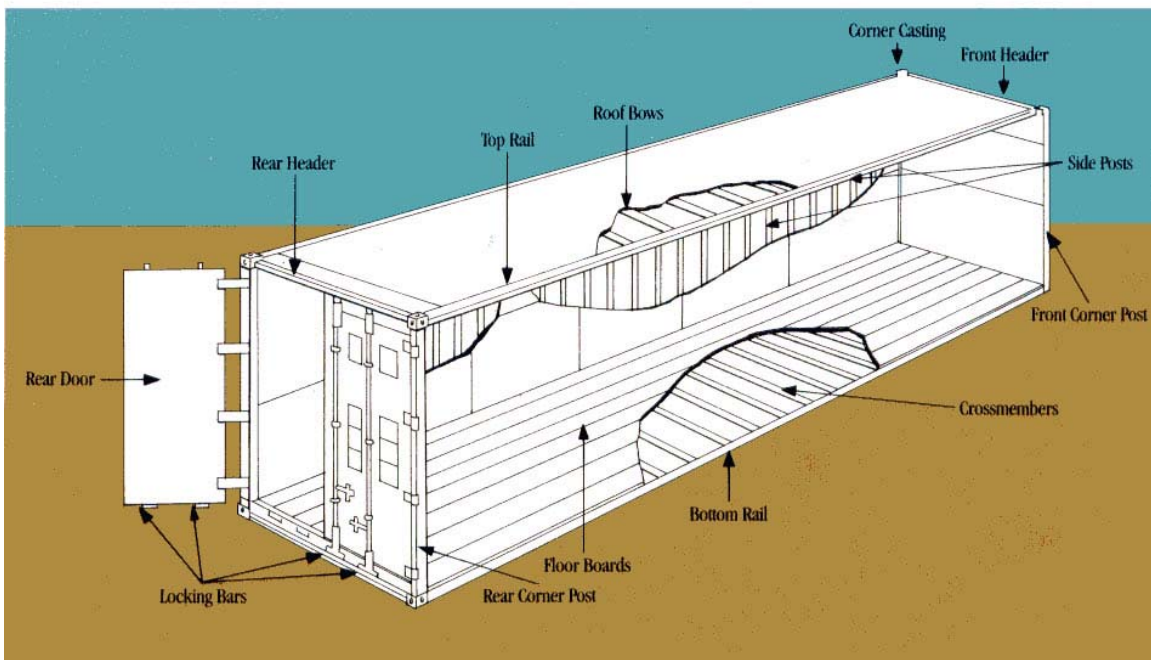
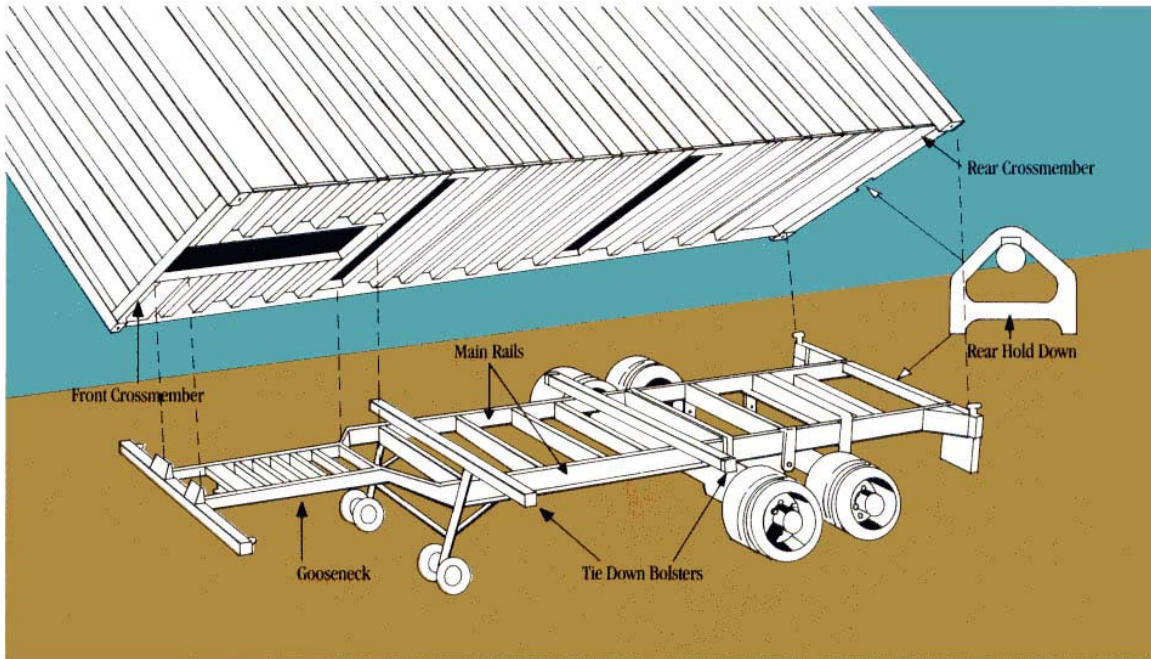

Intermodal Container and Chassis

SPECIALIZED CONTAINER INSPECTION

In addition to the previous container inspection steps, if you are utilizing a refrigerated, tank or other special purpose container, check the following:

Motors/Compressors — Check to see that they are in good operating condition and perform as required. Be sure that adequate fuel has been supplied.

Fittings, Valves/Piping — They must be free of leaks with tight fittings. Valves should operate smoothly and seal tightly.

Electrical—Wiring and connections should be secure, watertight and free of corrosion. Switches should operate properly. Be alert for potential shock hazards.

STOWING CARGO

PREPARING THE CARGO

An intermodal container is essentially a ship's hold on a reduced scale. When the containers are placed aboard ship for an ocean voyage, the cargo stowed in them is subject to the same forces and damage hazards while at sea that affect cargo shipped in break-bulk fashion.

The same principles and techniques that govern export packing and cargo stowage of break-bulk shipments are equally valid when preparing cargo for intermodal shipment.

Pack For The Toughest Leg Of The Journey!

Refer to the Basic Packing Guide section of this booklet for guidance in selection of packaging.

Be certain that goods cannot move within the fiberboard box, wood crate or other shipping package. Immobilize the contents by blocking or bracing and/or providing adequate cushioning.

Fiberboard boxes or wood crates must be able to withstand the weight of cargo stacked up to an 8-foot height. They must be able to survive lateral pressures exerted by adjacent cargo—up to 70 percent of the vertical stacking weight pressure. This will help to prevent crushing as the container leans (up to 45°) during handling or at sea.

Heavy items, machinery and cargo not uniform in shape or dimension should be crated, boxed and/or provided with skids to permit ease of handling and compact stowage.

Where possible, cargo should be uni-sized or palletized. Cargo handlers are then required to use mechanical handling equipment to move cargo. The "Pennsylvania", one of the first iron steamships built in America expressly for ocean-going commerce.

Provide adequate water damage protection. Use of desiccants (moisture-absorbing materials), moisture or vapor barrier paper, plastic wraps, sheets or shrouds will protect cargo from water contact or condensate damage. Corrosion susceptible machine parts should be coated with a preservative or rust inhibitor.

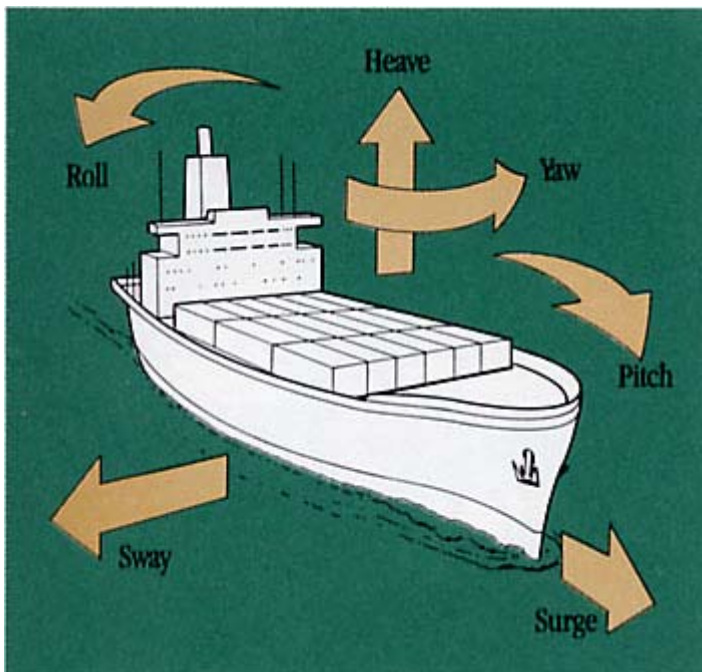

A ship at sea may move in six different directions.

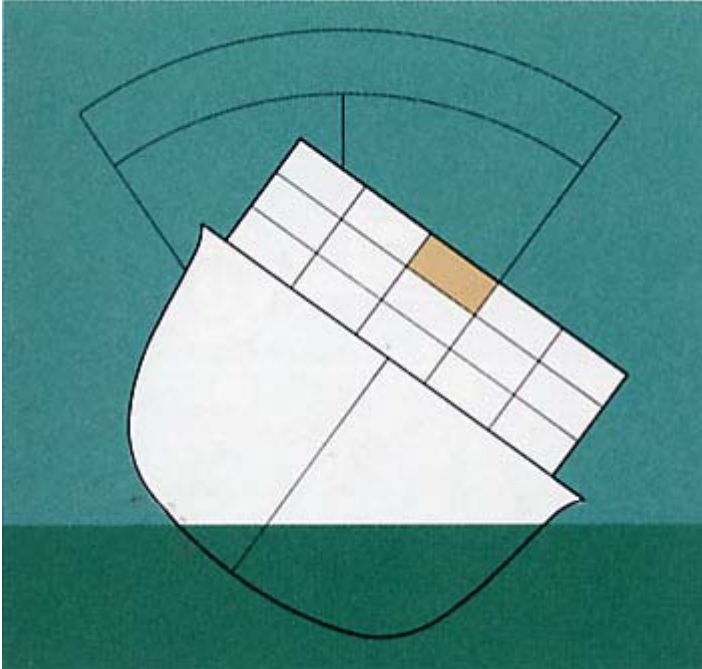

This container may travel 70 feet with each complete roll; as often as 7 to 10 times per minute

PLAN THE STOW

Observe Weight Limitations

Do not exceed rated capacity of package or intermodal container. Do not exceed permissible weight concentrations per square foot of floor load. Check highway weight-axle limitations on both sides of the ocean voyage because some containers have total capacities that exceed local limits.

Avoid Mixing Incompatible Cargo

Cargo that emits odor or moisture should not be stowed with cargo susceptible to tainting or water damage. Items with sharp projections or awkward shapes should be segregated from other cargo by boxing, crating, padding or use of partitions. Cargo subject to leakage or spillage should not be stowed on top of other cargo.

Observe Hazardous Material/ Dangerous Goods Regulations

Consult with carrier/or regulations and restrictions regarding shipment of:

- combustibles
- explosives
- flammable liquids
- flammable solids
- gaseous materials
- radioactive materials
- magnetized materials
- spontaneous combustible materials
- corrosives
- poisons
- oxidizers
- infectious substances
- etiologic agents

After receiving information from carrier, proceed as follows:

Label and mark hazardous material/ dangerous goods properly. (See Hazardous Materials section.) Affix warning placards to container exterior. Note that placards vary throughout the world. What is acceptable at origin

may not be in compliance with enroute or destination countries' regulations. Check before shipment to avoid embargo or delay.

Record the nature of the cargo on all shipping documents.

Have All Cargo and Materials Ready Before Stowage Begins

Planning ahead facilitates proper placement, stacking and weight distribution. Additionally, it precludes removal of cargo already stowed to accommodate unexpected items, and permits installation of blocking, bracing and filling of voids as stowing operations progress.

Plan for Ease of Unloading

Stow cargo in reverse order of desired cargo discharge.

Be sure that cargo for multiple consignees is physically separated by partitions, dividers or other suitable means.

Make sure that forklift openings in pallets or skids face doors.

Fill any voids, but avoid wedging or jamming cargo in container.

Cosmetic Damage

The exterior packing of your commodity is often the first representative the consignee sees of your company. A package showing exterior damage, although perhaps only cosmetic in nature, can cause loss of market, poor shipper/consignee relationships and more importantly cause the goods to be rejected and/or not be paid for even though the contents may arrive without damage.

Repackaging commodities can be very costly as well as time consuming. Remember, the appearance of your product is in many cases as important as the product itself.

STOWING THE CARGO

Fiberboard Boxes

Fiberboard boxes containing tightly packed, dense items that support sides and ends of the box are stowed using the "bonded block" method. Fiberboard boxes containing lightweight or fragile items that provide little or no support to the box surfaces are stowed by stacking directly one atop the other. This method takes advantage of the vertical rigidity of the side walls and corrugations in each box.

Use plywood or lumber dunnage or fiberboard dividers as auxiliary decking sheets to segregate tiers of different sized fiberboard containers.

Provide plastic or water-repellent shrouds over top and sides of load to protect against damage from water (ship's sweat or leaking containers).

Use dunnage or pallets on the container floor to elevate the cargo and allow drainage should water ingress.

Fill all voids by bracing or using fillers to prevent sliding or shifting of cargo.

Fill end voids to prevent sliding or shifting of cargo.

Use of Retaining Paper

Use rough paper between stowage blocks of fiberboard containers with smooth exteriors to prevent sliding or shifting.

Lumber

Should be clean and dry (not above 19 percent moisture content).

1. Use suitable hardwoods as filler, decking, blocking, bracing and for constructing partitions/dividers.
2. Most common sizes used are nominal 2" X 4" and 4" x 4". Should be free of significant splits or knots.

Plywood

1. Use for partition faces, dividers, auxiliary decking and blocking in limited spaces.
2. Should be clean and dry.

Inflatable

Available in paper, fabric, rubber or plastic; in both reusable and disposable forms. A check for sharp edges and/or protrusions must be made to avoid punctures. Use it for filling voids; light and medium duty bracing.

Patented Systems

Various patented cargo control and dunnage systems are available. Pre-built partitions, shelves, straps, laminated linerboard bulkheads and dunnage bars facilitate stowage and securing of cargo.

Fiberboard

Available in sheets, rolls and in prescored structural shapes. Use sheet for dividers, decks, partition facings and auxiliary decks.

Use rolled fiberboard sheets (solid or corrugated) for linings or facings and for filling voids.

Strapping

Heavy duty metal strapping is used to separate cargo units and for securing heavy or awkward items.

Nonmetallic strapping is used for light-weight cargo and has only a fraction of the strength of similar steel material. It would not resist shearing on a sharp edge, and will stretch as much as 9 percent.

Metal and plastic straps must be firmly anchored and properly tensioned.

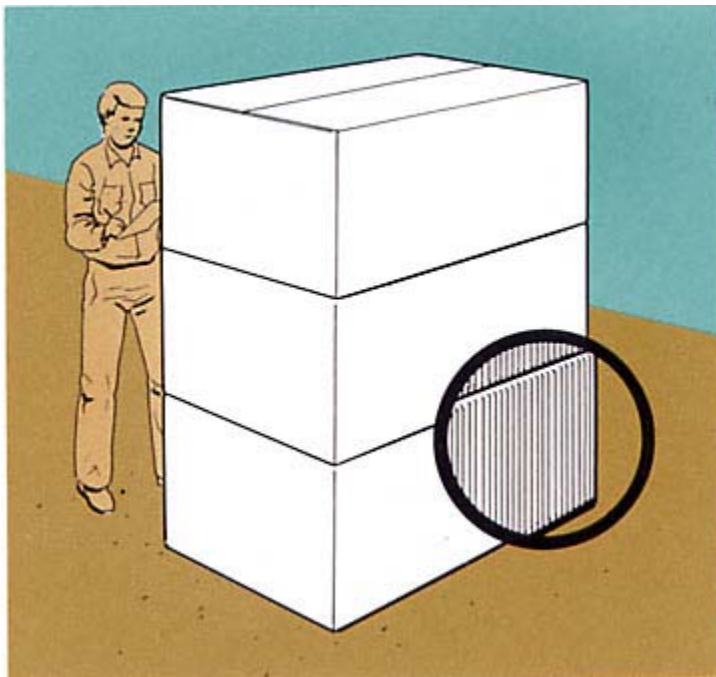

Vertical positioning of corrugated flutes provides best support for stacking

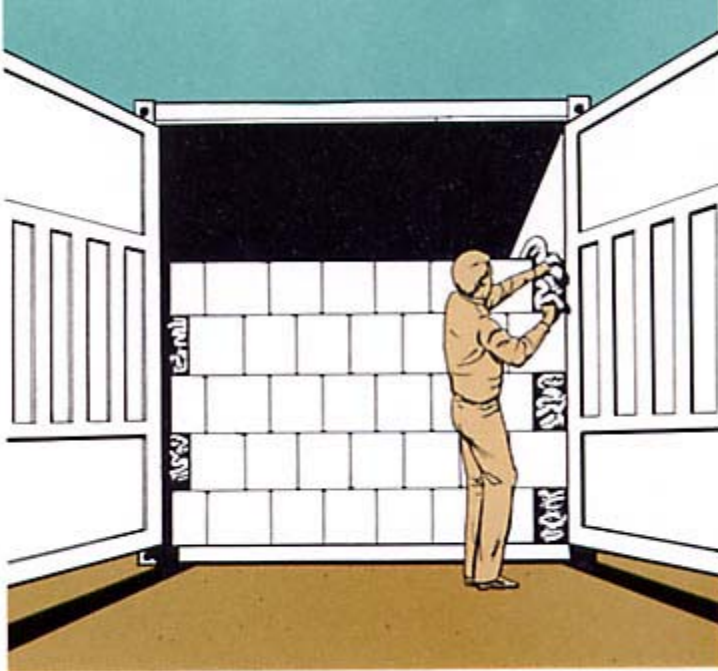

Fill side and end voids to prevent movement of cargo.

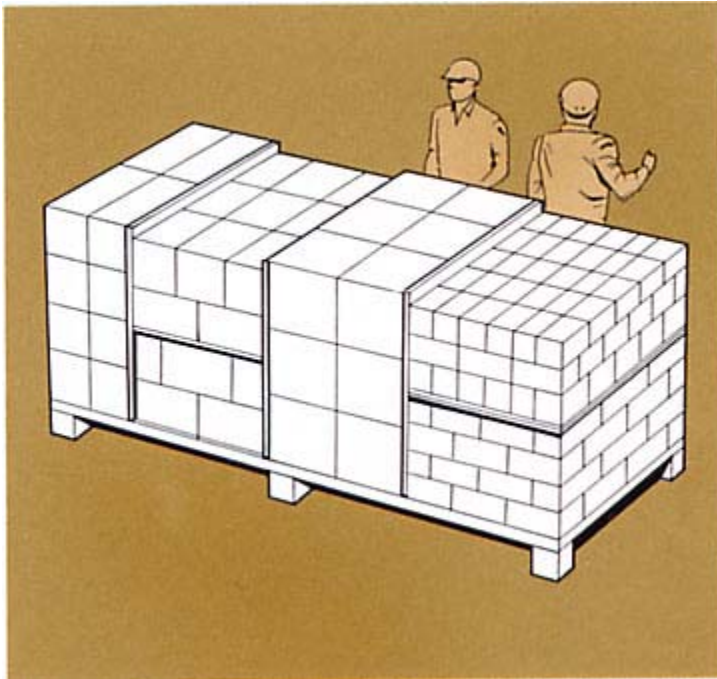

Use of dividers and auxiliary decks to segregate cargo by type, size or destination.



When stacking directly on top of lower boxes, keep voids at the center and immobilize by constructing partitions or inserting inflatable securing materials.

WOOD CRATES

Wood Boxes and Crates

Crates of uniform size and weight should be stacked directly one atop another.

Separate groups of crates with different weights or dimensions by use of partitions, dividers or auxiliary decking.

Fill voids at top, sides or ends by use of partitions or fillers.

If large voids are present, block, brace and tie down cargo to prevent movement in any direction.

When bracing crates, apply bracing to strength members only, not to panels or sheathing.

Machinery or Heavy Items

Distribute weight by proper placement and use of cradles or skids.

Use deck cleats and bracing to prevent lateral and fore-and-aft movement. Use metal strapping to prevent vertical movement.

Extremely heavy dense items should be properly secured to the container floor. Consult with carrier or container leasing operator for approved method(s).

Top-heavy items should be shored and braced to prevent toppling. Do not brace against the side panels of the container. All bracing must bear on a structural member of the container. Diagonally positioned bracing to the container floor is preferable for cargo that is top heavy.

Provide plastic or water-repellent paper shrouds over the top and sides of the item to prevent water damage.

Bags, Sacks and Bales

Use "crosstier" method of stacking bags and sacks. (Refer to illustration.)

Use sufficient dunnage layer on container floor to provide for condensate drainage.

Separate bags, sacks and bales from other cargo by using partitions.

When stowing bales, provide dividers between rows and tiers to prevent chafing and friction between metal bands or strapping.

Liquid Cargo (Drums)

Drums of liquid cargo should be separated from other cargo by use of partitions. Use adequate dunnage between tiers of drums to provide a level flooring surface for stacking.

Drums containing liquids should be floor loaded. The drums should be stowed on end with filler holes up as opposed to on their "rounds." Use dividers to protect drum rims from chafing damage.

COMPLETING THE STOW

Isolate Cargo From Container! Jailer/Railcar Doors—Construct partition across rear of stowed cargo to prevent it from contacting doors and falling out when doors are opened.

Provide Water Damage Protection—Cover cargo adjacent to doors with plastic or waterproof paper sheets to protect cargo from possible water ingress via door gaskets.

Close and Seal Doors—Be sure all locking cams are engaged. Affix locks and seals. (On units with side and end doors— be certain to check both.) Record seal number and enter on shipping documents.

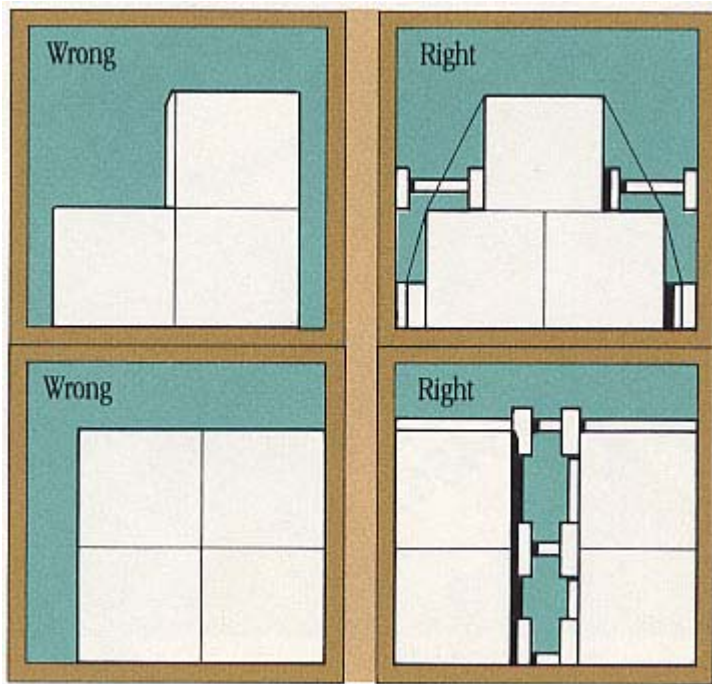

Weight Distribution – Heavy Loads

Wrong

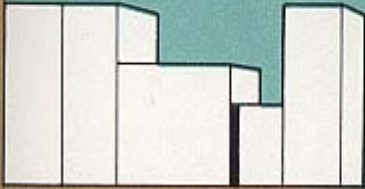

Right

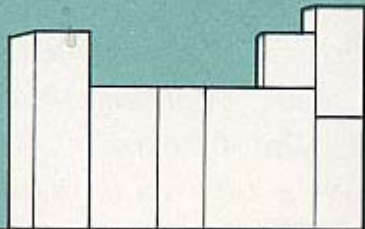

Right

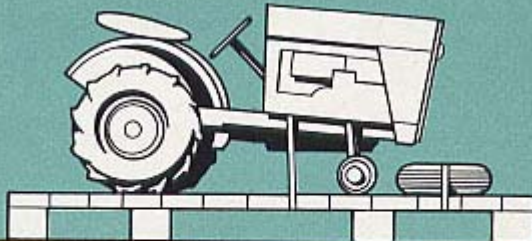

Right

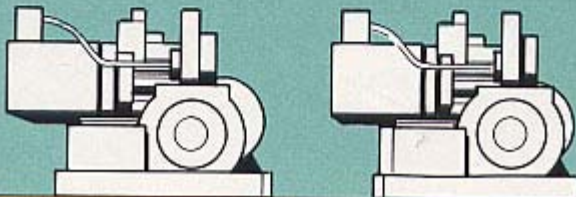



Bags and Sacks "Crosstier" Loading

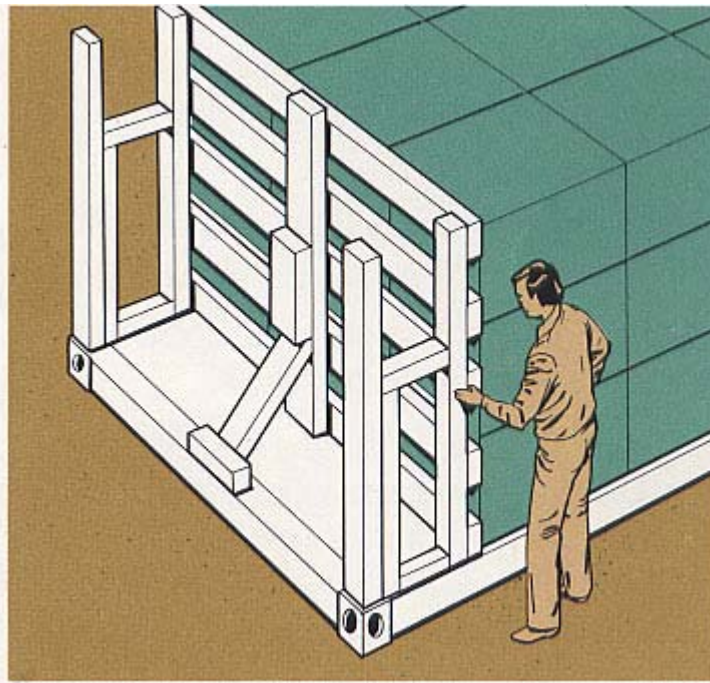

Bracing the completed load to prevent movement aft



CARGO SECURITY SEALS

As previously noted, once loaded, all in-termoal and air cargo containers, trailers and railcars should be sealed. The particulars of a shipment, namely product type, value, marketability, susceptibility and routing/destination should be considered prior to seal selection. The most popular seal, usually constructed of polypropylene or galvanized tin plate can be breached and, even re-fitted, with basic tools. Stronger heavy duty cable seals or high security seal locks offer additional protection as they generally deter all but the most determined thief. In addition to deterring physical entry of the container, trailer or railcar, other desirable properties of seals include:

- Unique and clearly visible identity.
- Corrosion — resistance especially for those containers destined for ocean carriage.
- Tamper-proofing so that it is impossible to re-fit.
- Strong enough to withstand accidental damage during handling/transit.

Technology has allowed for several sophisticated variations on these themes. Today, a shipper can choose from several seal types. There are bar-coded seals that enable automatic recording of seal numbers, indicator seals that release a bright dye into a transparent casing that is clearly visible from considerable distances and, at least, one manufacturer has developed a seal consisting of randomly set acrylic optical fibers jacketed in a high impact plastic body. These seals each have a unique "fingerprint" that can be verified by a specially designed camera.

Regardless of the type seal used, its value is compromised if application is not properly supervised and it is not inspected at regular intervals during transit. Effectiveness is also only as good as the controls maintained over seal inventory. Seals should be stored in a controlled area and released to as few people as practical. A log indicating to whom seals identified by number, have been released, is a necessary control measure.

Through the years, the function of a seal has been to reveal evidence of entry. Given time, opportunity, and, in some cases, tools all can be defeated. Also, hi-jacking, the stealing of the entire trailer or container and contents, is a real potential. (With seals serving only to inconvenience the perpetrator[^]). In fact, in some areas of Africa, South America and Southern Europe, this is becoming a major concern.

Aside from compliance with proven in-transit security procedures such as direct routing and convoying, vehicle/cargo tracking is a viable alternative given certain cost and geographical constraints. The global network of satellites and land-based terminals enables two-way messaging between a vehicle and a central location.

This real time communication and periodic positioning capability has cargo security implications. Available system enhancement options include driver paging, vehicle diagnostics and refrigerated trailer monitoring.

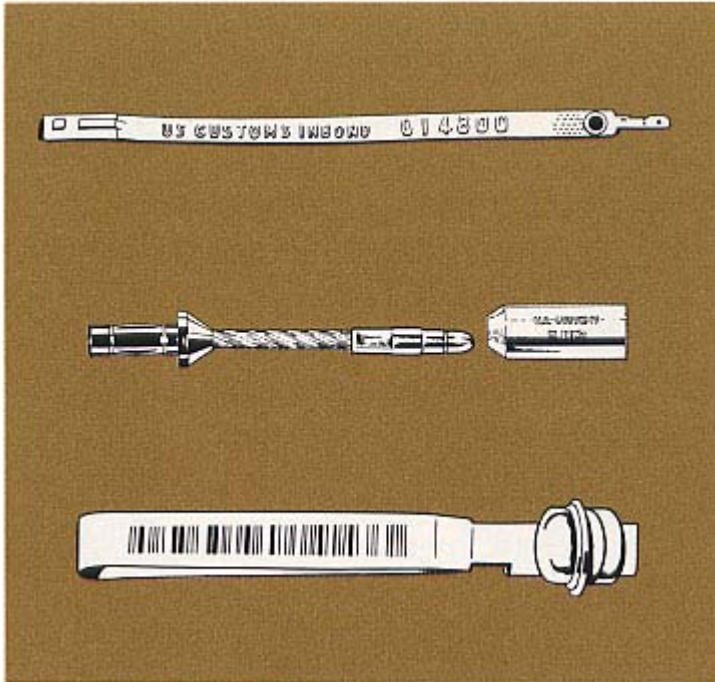

Custom Seals



Serialized Indicative Seal

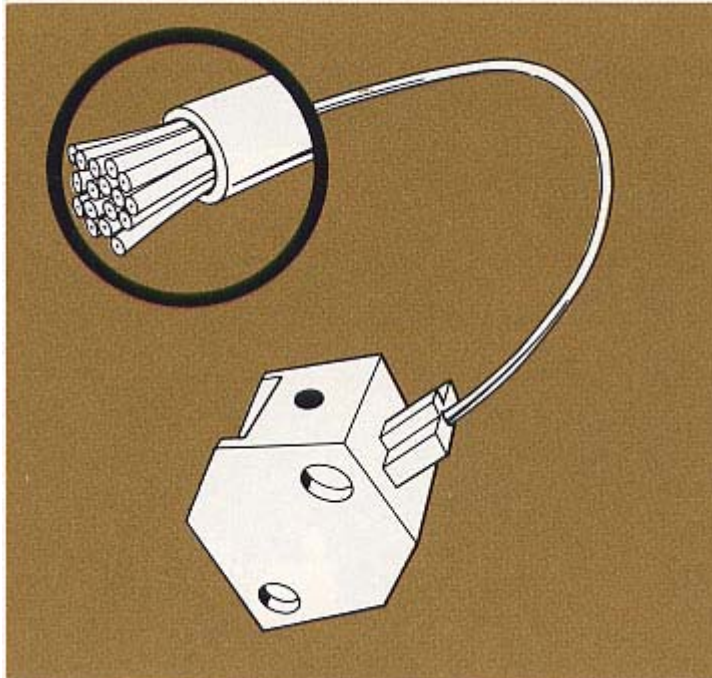

Fiber Optic Seal

AIR CARGO

Air cargo service has become more attractive to shippers as aircraft capacity, frequency of lifts, handling facilities and the number of locations serviced have been increased.

Air cargo losses can be controlled with the shipper as the key figure in effective loss control. Recognition of the hazards involved, packing cargo to survive the toughest leg of the journey and prudent selection of transportation services will assist the shipper in realizing successful loss-free delivery of his or her goods.

Inadequate packing and improper marking of cargo are the leading causes of air cargo losses. It is in these areas where the shipper can effectively influence the sound arrival of goods.

THE AIR CARGO ENVIRONMENT HAZARDS

In The Aircraft

Acceleration/Deceleration-Fore-and-aft pressures are exerted on cargo during takeoff and landing. Compression forces are exerted during rough landings.

Turbulence-Rough or "bumpy" flight conditions subject cargo to rapid alternating vertical movements, imposing heavier pressure one moment, and almost weightless conditions the next.

Altitude-As altitude increases, atmospheric pressure decreases, subjecting liquid cargo to leakage hazards and pressurized cargo to increased internal pressure.

Temperature- Aircraft cargo compartment temperatures normally range between 30°F and 70°F (-1°C and 21°C). However, cargo aboard an aircraft parked in freezing or very hot weather will be subjected to unusual cold or heat conditions.

Cargo Compartments - The main cargo compartments of air freighters are normally well equipped for adequate stowage. Passenger aircraft belly compartments, however, are often loaded with limited cargo restraint equipment permitting the possibility of movement during flight and inviting damage from adjacent cargo.

In Terminals

Handling - Many larger terminals are equipped with conveyor systems and mechanical cargo handling gear, permitting rapid and safe movement within the terminal. Manual handling involves the stacking of cargo on pallets and in containers. In smaller terminal facilities, it is the rule. Overcrowded conditions contribute to handling damage as cargo may be stacked above recommended heights or re-positioned frequently.

Storage - Modern terminals provide segregated security areas for high value cargo, and some have cold storage (reefer) facilities for perishables.

Terminals not so equipped are subject to increased theft, pilferage and deterioration loss hazards. Overcrowded conditions may also require storage of some cargo outdoors, exposing it to the elements.

Ramps - Cargo is exposed to the weather while enroute to loading ramps. If cargo transfer carts, pallets and containers are not adequately covered (tarped), water damage may result. High-value cargo is particularly susceptible to theft when not in the aircraft or the terminal.

Security- Security-conscious carriers provide maximum physical measures to protect cargo from theft or pilferage. Examples include restricting working areas to employees, applying modern locking and alarm devices and enforcing strict cargo documentation procedures. When these measures are not enforced, cargo security is jeopardized.

Dangerous Goods - Only trained personnel should handle this cargo. Consult appropriate publications for guidance such as the ICAO *Technical Instructions For The Safe Transport of Dangerous Goods by Air* or IATA *Dangerous Goods Regulations*.

On Trucks

Most cargo is delivered to both carrier and consignee by truck.

Often, air cargo is stored in ware-houses or on transfer docks before forwarding, increasing exposure to theft, pilferage and handling damage. **INSIST UPON PROMPT PICKUP AND DELIVERY OF YOUR CARGO!** This is the most effective means of reducing exposure to loss.

Preparing Cargo For Air Shipment/ Pack For The Toughest Leg Of The Journey:

Trucking to air terminal, handling in terminals, stowing in aircraft, inflight, unloading aircraft, transfer to terminals, truck transport to consignee.

Cargo Should Be Packed To Withstand: Stacking up to 8 feet high, pressure from adjacent cargo, crushing action of tie-down straps, manual handling, exposure to the elements.

Unitize, Palletize, Containerize To: Minimize manual handling, reduce incidents of lost or stray items, limit exposure to theft and pilferage, and minimize stowage damage. Provide water-protective coverings, which will accompany pallet and unit loads on entire journey.

Liquid Cargo

Do not fill containers completely-

Provide expansion space to compensate for temperature and/or pressure variations. Be sure all caps, valves and seals are tightly closed. Put orientation marks (arrows) on all sides of package.

Large, Heavy or Awkward Cargo

Check with carrier to determine allowable aircraft floor weight concentrations.

Provide skids for ease of mechanical handling.

Check dimensions to be sure cargo will pass through aircraft loading doors.

Provide adequate locations for application of tie-down straps.

Water Damage Protection

Pack cargo in wooden crates with waterproof paper or polyethylene liners.

Line non-impregnated fiberboard boxes with waterproof paper or polyethylene.

Large items can be shrouded with polyethylene sheeting. Be sure there are drain holes in the base of the crate.

Use desiccants (moisture absorbent materials) in conjunction with waterproof barrier wrapping when packing moisture sensitive items.

Use shrink wrap, stretch wrap or plastic shrouds on unit and pallet loads.

Perishable Cargo

Provide adequate package ventilation where required. Furnish appropriate instructions i.e., carrying temperatures and handling requirements, to carriers. Use direct flights where possible. Delivery and pick-up should be closely timed with aircraft departure and arrival.

Marking

Avoid marks and advertising that reveal contents are of a valuable or desirable nature. Apply appropriate coded identification marks to at least three sides of item. Use international handling symbols. Include handling instructions in both English and the language of the country of destination. Use indelible inks and water-proof labels.

AIR CARGO CONTAINERIZATION

Shippers can realize savings and minimize cargo loss by containerizing their air cargo shipments. Airlines encourage use of containers by providing special tariffs for containerized FAK (Freight-All-Kinds) shipments on many routes.

Certain commodities are excluded from air cargo FAK special rates. Consult with your carrier or forwarder for specifics on excluded items and on articles prohibited by IATA's *Dangerous Goods Regulations*.

Air carriers prefer containerized shipments for a number of reasons:

Reduces the number of individual pieces of cargo that must be handled in terminals.

Provides for most efficient use of cubic capacity of the aircraft.

Permits use of mechanical handling systems and equipment to best advantage.

Speeds loading and unloading of aircraft.

Minimizes exposure of cargo to weather, theft, pilferage and handling damage while in custody of the carrier.

Air Cargo Containers Fall into Four Basic Categories

1. Air Cargo Pallets

Designed for use with conveyor systems in terminals and in aircraft. The low-profile flat pallet is equipped with fittings for securing the pallet firmly to the main deck of an all-cargo aircraft. Cargo is normally secured to the pallet by use of cargo nets, tightened over cargo by the application of tensioned straps.

2. Contoured Air Cargo Containers

Contoured, semi-structural covers called Type "A" are used to provide protection for cargo and keep cargo within safe dimensions for loading in aircraft.

These containers may have one side (front) open, with cargo secured by nets or have metal or fiberglass removable doors, which are capable of being sealed.

3. Lower Deck Containers

Developed for use in the lower deck cargo spaces of high-capacity aircraft, they are fully structured and completely enclosed.

Cargo is loaded into the container, which may be equipped with shelves for accommodation of small or irregularly shaped cargo.

The container doors of metal, fabric or a combination of both are closed and sealed.

Containers are locked directly into air-craft restraint systems without need for nets or tie-downs. Provide dunnage or shelving to prevent crushing of cargo at recessed end of lower deck

container.

4. Box-Type Containers

Developed in standard sizes to facilitate establishment of uniform shipping rates, they are used to consolidate shipments.

Box-type containers are often used by freight forwarders to consolidate shipper's cargo into one easily handled and rated unit.

These containers are constructed of wood, fiberglass, plywood, fiberboard, metal or combinations of these materials.

Air/Land Containers- Introduction of the 747-class freighter has permitted adding an air dimension to the intermodal container. Lightweight 20- and 40-foot containers permit land and air transportation without rehandling or reloading.

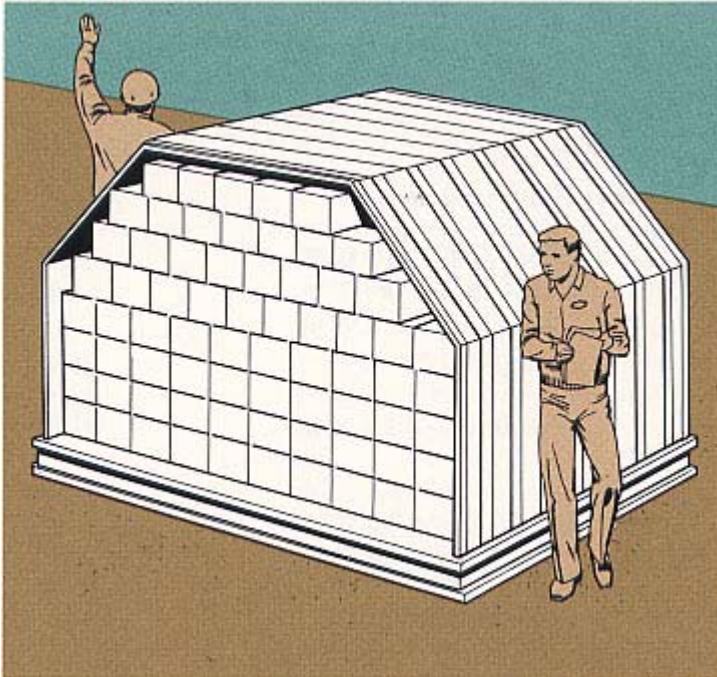

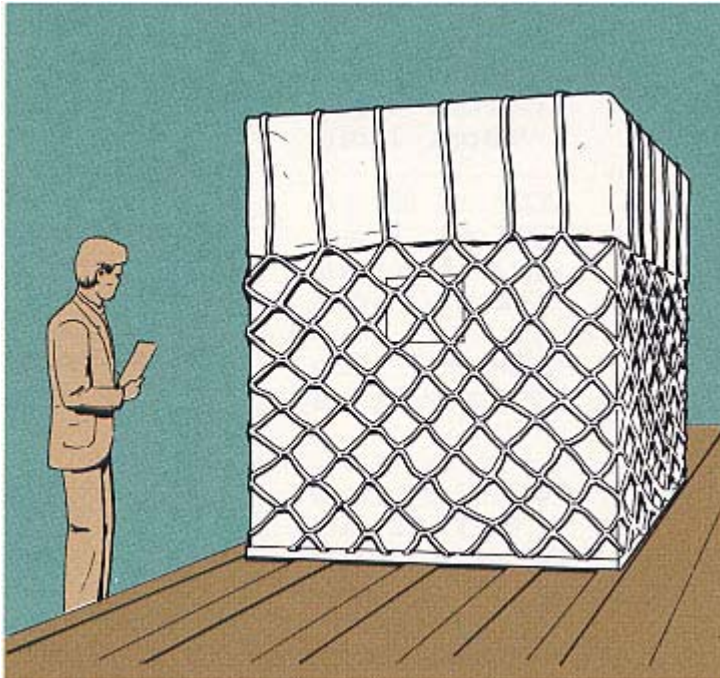
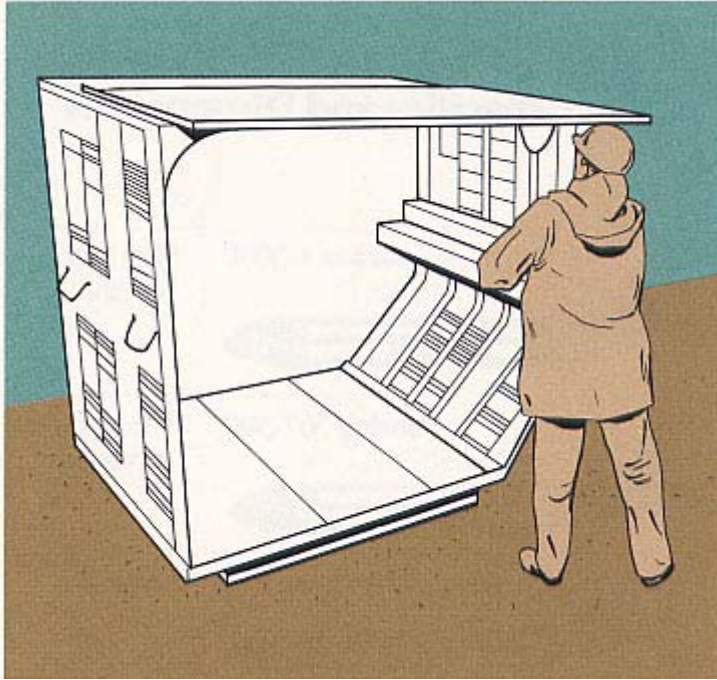

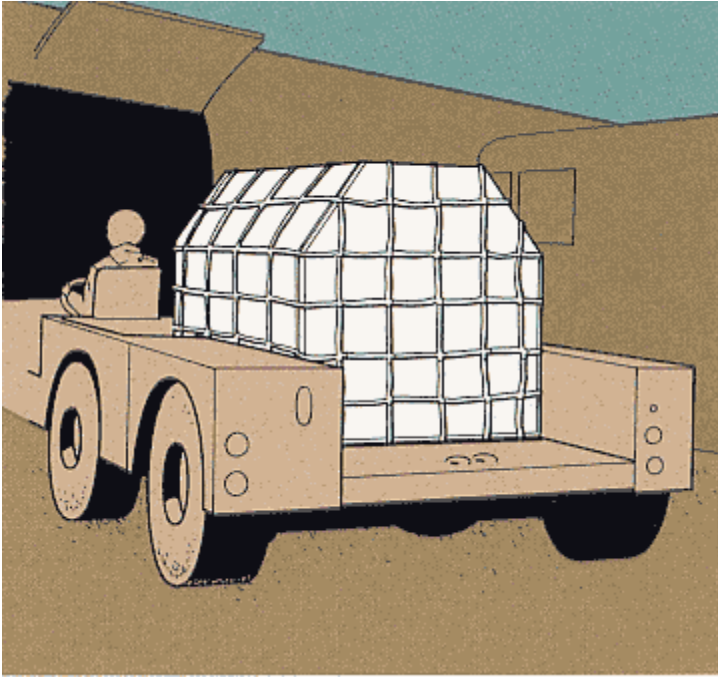

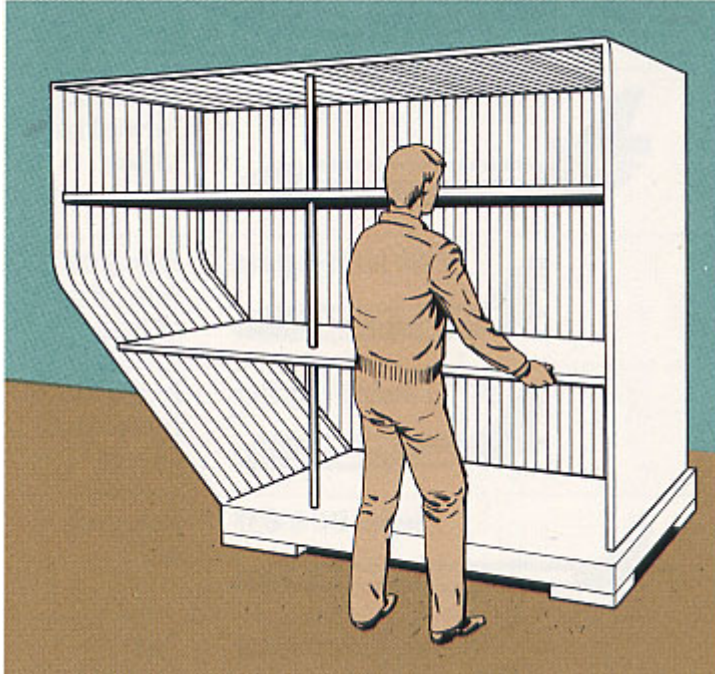

















Provide dunnage or shelving to prevent crushing of cargo in contoured end of lower deck container.

Aircraft Capacities and Dimensions

		Cubic Capacity	Maximum freight capacity	Access door dimensions	
	Airbus A-300C	Main deck Forward Aft	7,169 cu.ft. - 203 cu.m. 1,896 cu.ft. - 53.7 cu.m. 1,264 cu.ft. - 35.81 cu.m.	111,763 lbs - 50,695 kgs (total freight capacity)	101" x 141" - 257cm x 358cm 95.9" x 67.5" - 24.3cm x 171cm 71.3" x 67.4" - 181cm x 171cm
	Boeing 767-300	Main deck Forward Aft	3,600 cu.ft. - 101.9cu.m.	69,850 lbs - 31,684 kgs	AFT 700" x 69" - 178cm x 175cm
	Boeing 757	Forward Aft	700 cu.ft. - 19 cu.m. 1,090 cu.ft. - 30 cu.m.	25,700 lbs - 11,657 kgs (total freight capacity)	FWD 55" x 44" - 140cm x 112cm AFT 55" x 44" - 140cm x 112cm
	Boeing 747C	Main deck Forward Aft Bulk compartment	9,145 cu.ft. - 259 cu.m. 2,225 cu.ft. - 63 cu.m. 742 cu.ft. - 21 cu.m. 1,271 cu.ft. - 63 cu.m. 800 cu.ft. - 22.6 cu.m.	92,000 lbs - 41,500 kgs 55,500 lbs - 25,175 kgs 20,400 lbs - 9,250 kgs 22,600 lbs - 10,280 kgs 14,800 lbs - 6,750 kgs	134" x 120" - 340cm x 305cm 104" x 66" - 264cm x 168cm 104" x 66" - 264cm x 168cm 44" x 47" - 112cm x 119cm
	Boeing 747F	Main deck Forward Aft Bulk compartment	21,270 cu.ft. - 602 cu.m. 2,528 cu.ft. - 72 cu.m. 2,212 cu.ft. - 63 cu.m. 800 cu.ft. - 22.6 cu.m.	260,000 lbs - 117,936 kgs (total freight capacity)	134" x 123" - 340cm x 312cm 104" x 68" - 264cm x 173cm 104" x 68" - 264cm x 173cm 44" x 47" - 112cm x 119cm

	Boeing 737	Main deck Forward Aft	2,730 cu.ft. – 77.3 cu.m. 875 cu.ft. – 24.9 cu.m.	39,000 lbs- 17,687 kgs (total freight capacity)	134" x 84.5"- 340cm x 214cm
	Boeing 707F	Main deck Forward Aft	8,000 cu.ft. – 227.2 cu.m. 875 cu.ft. – 24.9 cu.m. 910 cu.ft. – 25.8 cu.m.	90,000 lbs- 40,824 kgs 14,300 lbs- 6,486 kgs 13,900 lbs- 6,305 kgs	134" x 86.6"- 340cm x 224cm 48" x 50"- 122cm x 127cm 48" x 48"- 122cm x 122cm 35" x 30"- 39cm x 76cm (smaller rear door)
	Boeing 727-100C	Main deck Forward Aft	3,300 cu.ft. – 93 cu.m. 420 cu.ft. – 119cu.m. 470 cu.ft. – 133 cu.m.	37,960 lbs- 17,236 kgs (total freight capacity)	86" x 134"- 224cm x 340cm 48" x 35"- 122cm x 89cm 48" x 35"- 122cm x 89cm
	DC 10-30CF	Main deck Forward hold Aft Bulk Compartment	12,236 cu.ft. – 346 cu.m. 2,155 cu.ft. – 61 cu.m. 1,413 cu.ft. – 40 cu.m. 459 cu.ft. – 13 cu.m.	84,865 lbs- 38,495 kgs 56,000 lbs- 25,401 kgs 35,000 lbs- 15,875 kgs 7,480 lbs- 3,400 kgs	102" x 140 "- 259cm x 356cm 104" x 66 "- 264cm x 168cm 70" x 66 "- 178cm x 168cm 30" x 36 "- 76cm x 91cm
	DC 8F Jet Freighter	Main deck Forward hold Aft hold	5,092 cu.ft.– 144.2 cu.m. 688 cu.ft. – 19.5 cu.m. 724 cu.ft. – 20.5 cu.m.	83,790 lbs- 38,000 kgs 10,320 lbs- 4,690 kgs 10,470 lbs- 4,760 kgs	140" x 85 "- 356cm x 216cm 36" x 44 "- 91cm x 112cm 36" x 44 "- 91cm x 112cm
	DC 8 Combi Freighter	Forward cabin Forward hold Aft hold	1,600 cu.ft. – 45.2 cu.m. 688 cu.ft. – 19.5 cu.m. 724 cu.ft. – 20.5 cu.m.	8,000 lbs- 3,600 kgs 10,320 lbs- 4,690 kgs 10,470 lbs- 4,760 kgs	140" x 85 "- 356cm x 216cm 36" x 44 "- 91cm x 112cm 85" x 140"- 216cm x 356cm
	Super DC 8-63F	Cabin Forward hold Aft hold	10,331 cu.ft. – 293 cu.m. 2,500 cu.ft. – 71 cu.m.	119,000 lbs- 54,000 kgs (total freight capacity)	85" x 140"- 216cm x 356cm 63" x 54"- 160cm x 137cm
	DC 9-33RC Freighter	Main deck Aft	2,680 cu.ft. – 76 cu.m. 420 cu.ft. – 11.9 cu.m. 318cu.ft. – 9 cu.m.	33,297 lbs- 15,135 kgs 6,952 lbs- 3,160 kgs 5,000 lbs- 2,265 kgs	113" x 81"- 341cm x 203cm 53" x 50"- 135cm x 127cm 36" x 50"- 91cm x 127cm
	DC 9-15	Forward hold Aft hold	373 cu.ft. – 10.5 cu.m. 227 cu.ft. – 6.4 cu.m.	5,595 lbs- kgs 3,403 lbs- kgs	53" x 50"- 135cm x 127cm 36" x 50"- 91cm x 127cm
	L1011-500F	Main deck Lower deck	12,066 cu.ft. – 342 cu.m. 3,415 cu.ft. – 98 cu.m.	146,500 lbs-66,518 kgs (total freight capacity)	134" x 100"- 340cm x 254cm
	MD-88	Main deck Aft	1253 cu.ft. – 35.5 cu.m.	18,795 lbs- 8,525 kgs	FWD 48" x 34"- 122cm x 86cm AFT 48" x 35"- 122cm x 89cm

The table below lists standard air cargo containers. Minor variations in internal dimensions and cube will occur due to differences in the construction techniques and materials used.

Air cargo is a popular mode of transportation for live animal shipments. Consult individual airlines for specific requirements and restrictions. Equally important, check on the import regulation and quarantine laws that affect shipments.

Air Cargo Containers. The following is a brief description of the various containers used.

External Dimensions (inches)	Mazimum Gross Weight(lbs.)	IATA	ATA
125 x 96 x 96	15,000	ARA	M1
240 x 96 x 96	25,000	ASE-ASG	M2
88 x 125 x 87	13,300	SAB-UAB	A1
88 x 125 x 87	12,500	AAA-SAA	A2, A3
81 x 60.4 x 62.75	4,500	--	FTC
47 x 60.4 x 64	2,700	APA	LD2
79 x 60.4 x 64	3,500	AVE-AKE	LD3
96 x 60.4 x 64	5,400	DLP-DLF	LD4
125 x 60.4 x 64	7,000	AWB-AWD	LD5, LD11
25 x 60.4 x 64	5,680	AWC-AWF	LD6
125 x 60.4 x 64	13,300	AAP-AAR	LD7, LD9
196 x 60.4 x 60	5,400	ALE	LD8
125 x 60.4 x 64	5,680	AWR-AWS	LD10
98 X 42.2 X 41.6	1,700	--	LDW
84 X 58 X 76.45	5000	--	B
42 X 58 X 76.45	2500	--	B2
58 X 42 X 45	2,000	--	D
42 X 29 X 25.5	500	--	E
35.4 X 21 X 21	250	--	EH
56 X 55 X 57	3,160	--	LD-N
39.5 X 27.5 X 21	400	--	Q

A BASIC PACKING GUIDE

EXTERIOR CONTAINERS

Fiberboard Boxes (Cartons)

The most common economical container continues to be the fiberboard box. This is understandable as shippers seek efficient, but inexpensive and lighter weight containers. It comes closest to fitting the description of the ideal shipping container, which is light in weight, of low cost, but able to withstand normal transportation hazards and protect the contents against loss or damage. The fiberboard box frequently measures up to most of these requirements in domestic transportation, but fails frequently in overseas movement when proper selection procedures are not followed. It must be recognized that all commodities cannot be suitably packed in fiberboard boxes. Moreover, all fiber-board boxes are not suitable overseas containers. This is particularly true be-cause increases in moisture content of corrugated fiberboard adversely affect its stiffness and compressive strength.

NOTE: Compressive strength may be reduced to approximately one-half normal strength by high humidity (90 percent r.h.+). More serious strength losses may occur with cyclic humidity. Impregnation or coating of the fiberboard will delay but not completely prevent this loss.

Illustrations of Solid and Corrugated Fiber Construction

First, the shipper must determine whether or not a fiberboard container is a suitable one for the particular commodity to be shipped, bearing in mind the item's vulnerability as well as the handling and transportation hazards to be encountered.

The actual selection of the box is the next logical step based on the following points.

1. The underlying factors in the selection of the fiberboard box are resistance to crushing, resistance to puncture, strength of the score lines and probably the most important - resistance to moisture absorption. Impregnated and multi-wall boxes are the most practical. Never use corrugated fiberboard boxes with a bursting test strength of less than 275 pounds per square inch. Corrugated fiberboard in export shipment applications should be constructed using water-resistant adhesives.
2. Flaps should be stapled or glued with a water-resistant adhesive applied to the entire area of contact between flaps. For further protection all seams can be sealed similarly.
3. Keep weight of contents within load limits specified in the box manufacturer's certificate. **NEVER OVERLOAD.**
4. Reinforce with two tension straps applied at right angles, and crisscross at top and bottom, or with two girth straps of filament tape.
5. When the nature of the contents permits, the load should support the walls of the box. Otherwise, the box should have sufficient resistance to compression to prevent collapse when placed in the bottom tier of a pile of similar boxes.
6. Full height partitions should be utilized to separate fragile items within the same fiberboard box and/or increase the stacking strength of the box.
7. Do not overlook economies and additional security offered by unitizing, palletizing or by overpacking several fiberboard boxes into consolidation containers. Highly pilferable merchandise is rarely safe in fiberboard boxes.

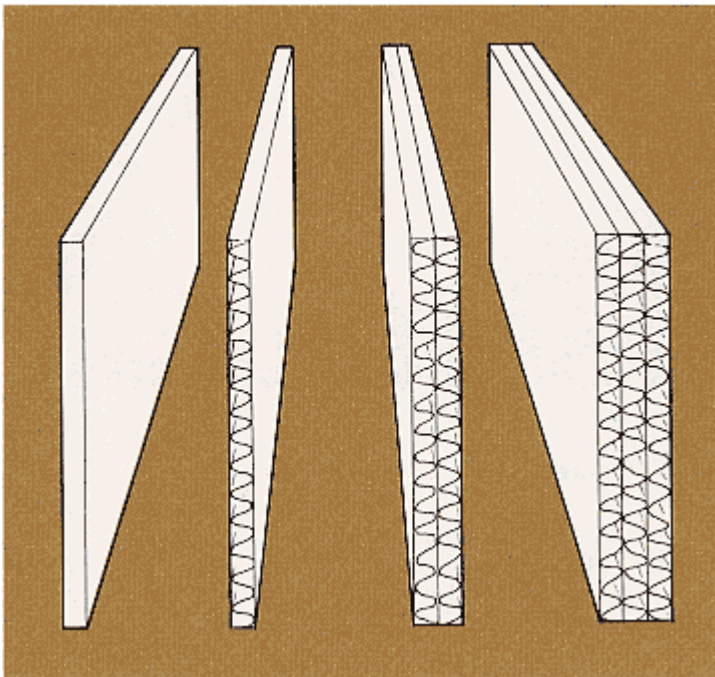
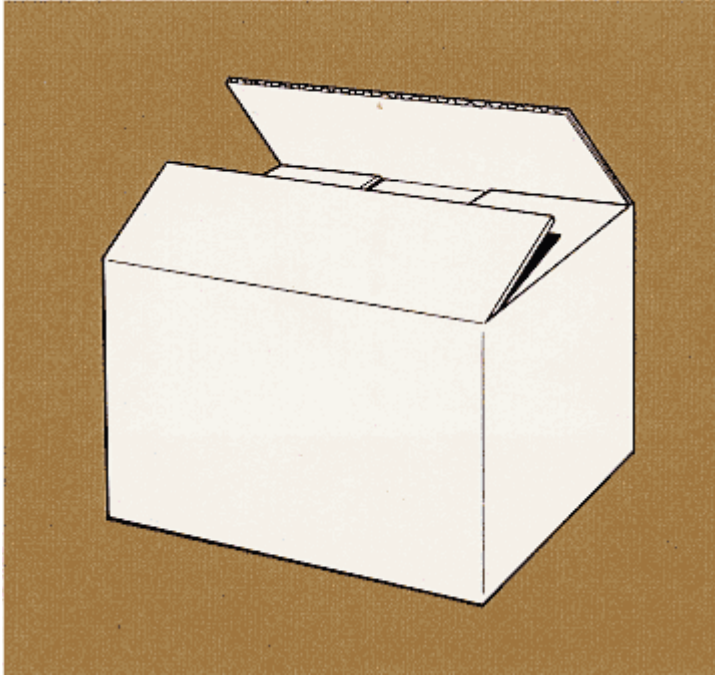

1. *Solid Fiberboard*
2. *Single Wall (Double Faced)Corrugated Fiberboard*
3. *Double Wall Corrugated Fiberboard*
4. *Triple Wall Corrugated Fiberboard*

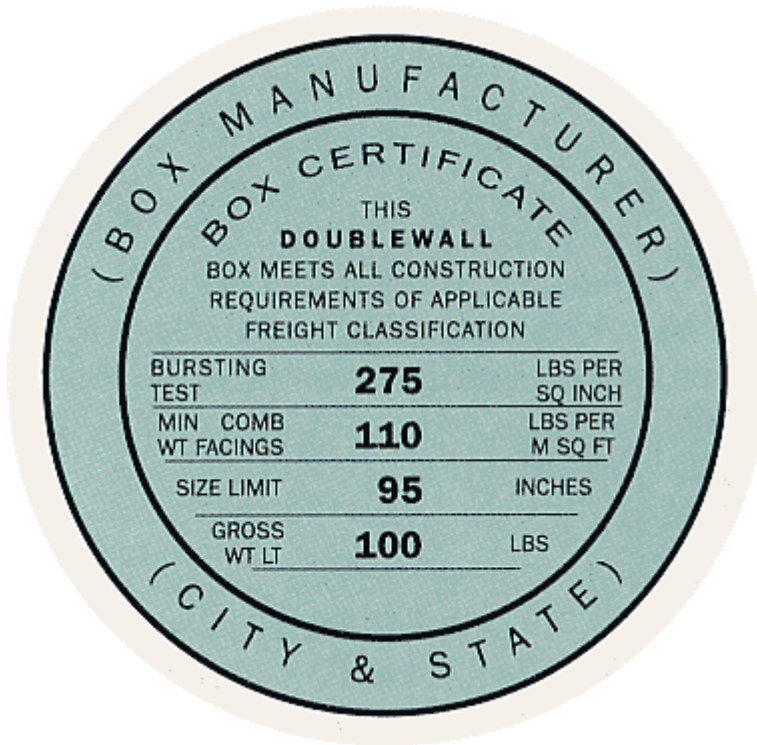

The circular form of certification indicated applies only to those fiberboard boxes that are constructed and used in compliance with Item 222 of the National Motor Freight Classification for truck shipments. Unless performance can be assured by a qualified testing laboratory, we would recommend using only those fiberboard boxes made and certified to comply with the aforementioned rules.

DO NOT use fiberboard with a bursting test of less than 275 lbs. per square inch for export shipping containers.

Nailed Wood Boxes

The nailed wood box is one of the most satisfactory containers for overseas shipment of moderate weight commodities.

Among its particular advantages are: ability to support superimposed loads; ability to contain difficult loads without undue distortion or breaking open; the protection it affords contents from damage due to puncture, breakage or crushing; and finally, the fact that it permits interior blocking to hold the contents in place, thus allowing the container to be turned on its side or upside down. The following recommendations should be considered in selecting the nailed wood box:

1. Boxes should be made up of seasoned lumber with moisture content between 12 percent and 19 percent. Knots should not be over one-third the width of the board, and specifically should not interfere with nailing. Severe cross graining should also be avoided.
2. Consult appropriate tables for selection of proper sizes of lumber and nails. Boxes with two or four cleats on each end are particularly recommended for overseas shipment.
3. Many a well-designed box fails because the load is not properly fitted or secured. If necessary, use proper blocking and bracing to adequately secure the load. A properly fitted or secured load should not move when the box is roughly handled. If the load must be kept upright, equip the box with lift handles, skids, top peaks, gables or some similar devices to assure the box being stowed and handled is in an upright position. **AVOID OVERLOADING.**

4. Reinforce the box with adequate tension metal straps placed one-sixth of the distance from the ends, unless boxes are in excess of 48 inches in length or over 250 pounds. Then, three or more straps should be used, with one for each additional 24 inches. Staples should be used to hold strapping in place when boards are five-eighths of an inch in thickness or greater.

5. DO NOT USE SECOND-HAND BOXES. They are deficient in strength and do not permit detection of pilferage.

6. Boxes should be equipped with corrugated fasteners or similar devices where contents are substantially valued and susceptible to pilferage.

7. Boxes should be lined with a waterproof barrier material sealed at the edge with a waterproof tape or adhesive to protect both the contents and the interior packing material.

<insert img here>

Crates

There are two general types of crates - the open or skeletal crate and the fully sheathed crate. Both types are dependent upon properly constructed frameworks. While the drawings below illustrate the comparative strength of frame members of open crates under vertical compression, the same principles apply to sheathed crates, as they also require diagonal bracing to make them rigid. Keep in mind that sheathing is provided to protect against exposure to the elements. The open crate can be used where contents are virtually indestructible, and packing is required only to facilitate handling and stowage. It also serves well as an overpack to consolidate fiberboard boxes or to provide unit pack stiffness to resist crushing. Three-way corner construction should be reinforced with diagonals.

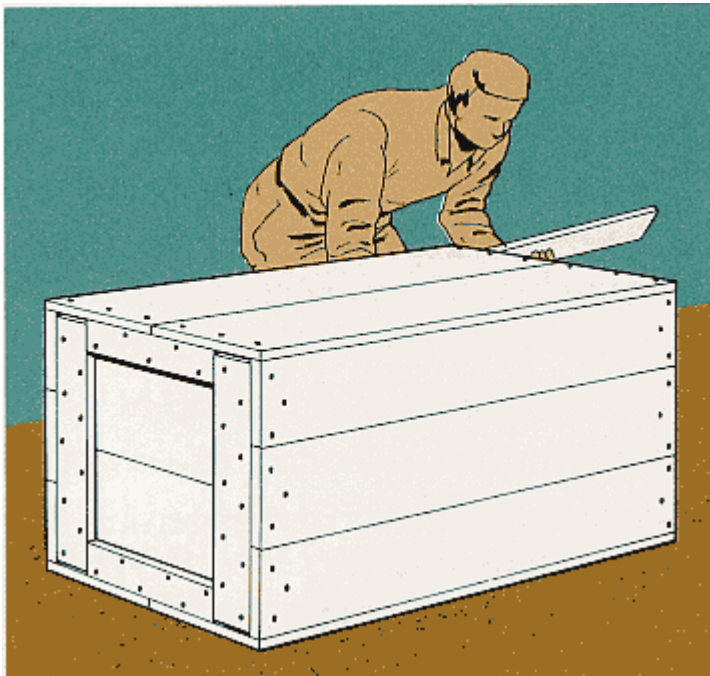

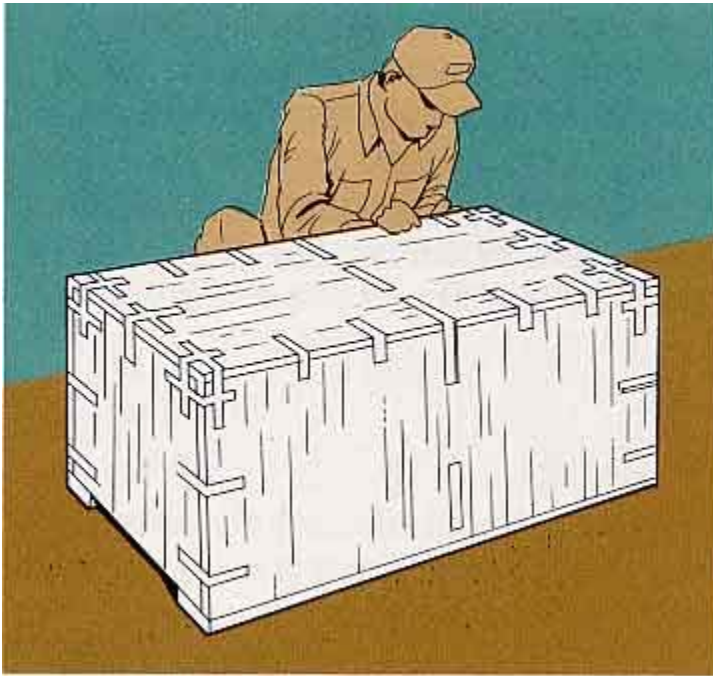
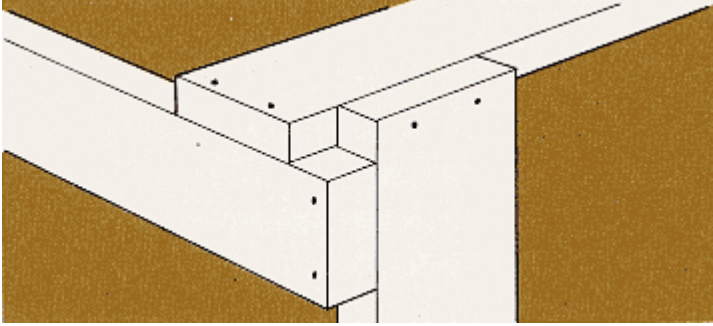
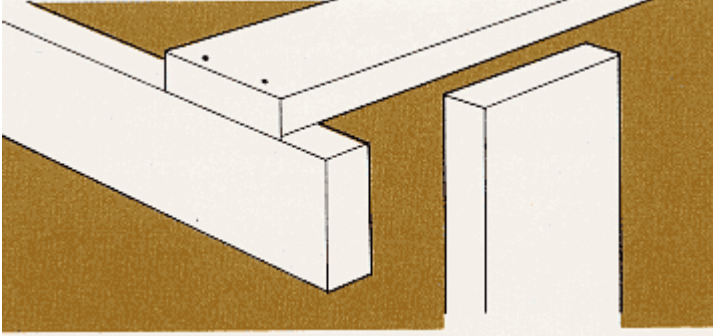

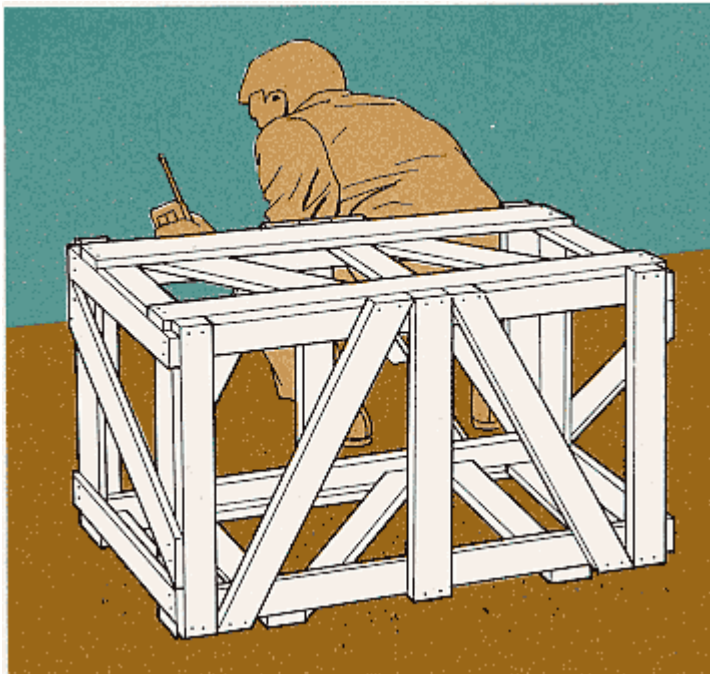
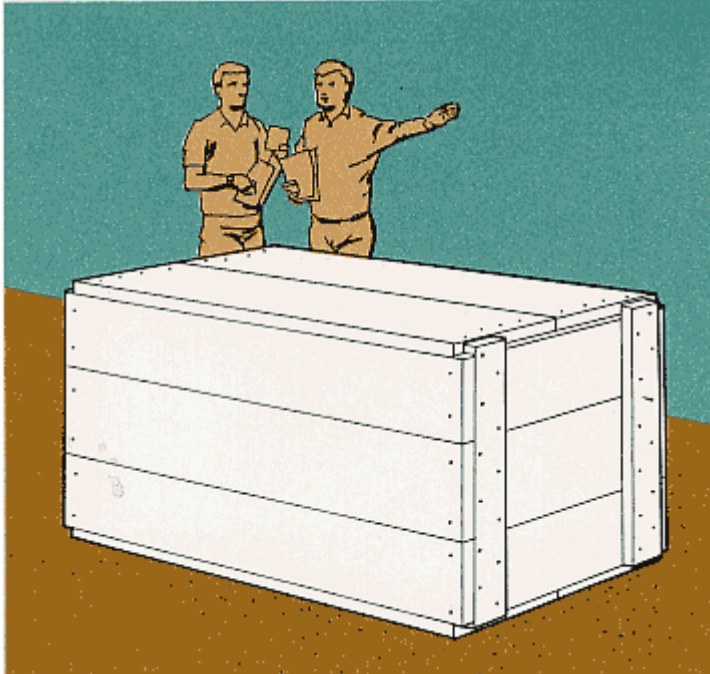

RELATIVE STRENGTH UNDER DIAGONAL COMPRESSION

Consider these points in sheathed crate construction.

1. Provide a **SUBSTANTIAL** framework, i.e., corner posts or vertical end struts, edge or frame members, intermediate struts and diagonal braces.

2. Large crates are usually stowed in the lower holds, hence they must bear great superimposed weights. Ensure top strength by frequent top joists under sheathing (never more than 30 inches apart). **DON'T** depend on end grain nailing **ALONE** to hold these joists. Supplement with back-up

cleats.

3. Reinforce floor at load-bearing points.

4. Design sides and ends for vertical sheathing.

5. On skid type crates terminate end sheathing at flooring to permit entry of forklifts. Terminate side sheathing $\frac{1}{4}$ inch short of skid bottoms to prevent tearing away of sheathing when crate is dragged sideways. The use of rubbing strips facilitates handling by forklift trucks.

6. On sill type crates provide lengthwise rubbing strips at base to facilitate handling and prevent tearing adrift of sheathing when the crate is dragged.

7. Where skids are used, be sure they are of sufficient dimensions and an adequate number provided. Skid ends should always be cambered, sling points provided and marked to facilitate vessel loading/ discharge.

8. Reduce cube and interior bracing problems by providing maximum disassembly of the carried item. Spares and disassembled parts should be adequately secured to crate interior. In doing so aim at a low center of gravity.

9. Line crate interior (except bottom) with a good grade waterproof barrier material. Ventilate crates containing machinery or other items susceptible to damage from condensation with baffled vents or louvre plates at ends or sides. Also, space floor boards $\frac{3}{8}$ inch apart.

10. Corners of all crates should be reinforced with lengths of 1 inch flat nailed strapping applied so as to tie together all faces at each corner.

11. Assure yourself that handling facilities are available for your crate at destination and at intermediate points. Provide consignee with opening instructions to reduce accidental damage during unpacking.

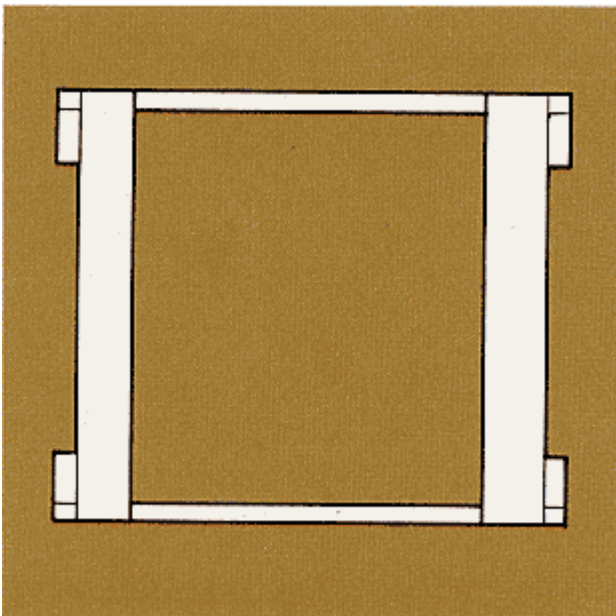

100 Units

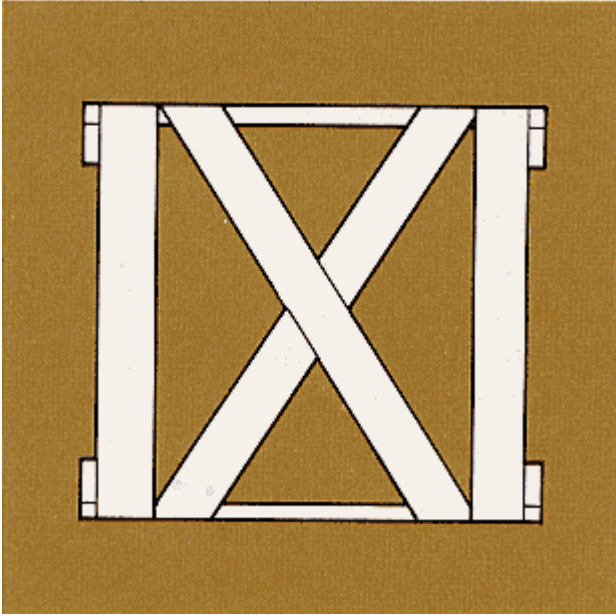

1,130 Units

Wirebound Crates and Boxes

Wirebound boxes and crates have shown themselves useful for a large variety of products not affected by minor distortions of the unit and as overpacks for solid or corrugated fiberboard boxes (cartons). If the wirebound container is not completely filled, properly applied interior blocking and bracing is recommended. The ends of wirebound containers should be reinforced to adequately resist forces that may be applied during handling thus preventing damage to contents. Shippers should **AVOID OVERLOADING** and should not use boxes too large for their contents. Other considerations are:

1. Veneer and cleats should be full thickness, straight grained and sound, free from knots, decay, mildew or open splits. Knots not more than 1.5 inches in diameter and less than one-third the width of the piece of veneer are allowable. Wire should be free from rust and scale.
2. Ideal staple spacing is 2.5 inches on crates; 2 inches on boxes. A minimum of two staples per slat is recommended.
3. Observe care in effecting closures to avoid wire fatigue. Use special closure tools,
4. Consult appropriate tables and your box supplier for export specifications.
5. Where contents are susceptible to pilferage or exceed 150 pounds, apply one tension strap lengthwise around top, bottom and ends. If over 250 pounds, apply two girthwise straps within 3 inches of each end. Also, consider applying straps over intermediate cleats.
6. Line box interior with a good grade waterproof barrier material and properly seal.

Cleated Plywood Boxes

Properly assembled and used, cleated plywood panel boxes have many uses in foreign trade. Their lightness and comparative strength particularly recommend them for air cargo shipments. Shippers may abuse these containers by using second-hand units, overloading, applying

strapping improperly, allowing long un-supported panels or failing to properly nail the box closed. Thin panels invite damage to contents through punctures. Follow these points:

1. Consult appropriate tables to avoid overloading, to determine proper nail spacing and to find correct dimensions of plywood and cleats. NEVER USE SECOND-HAND BOXES.
2. Reject rotted, split or otherwise defective cleats.
3. Apply intermediate cleats to all panels in excess of 24 inches.
4. Apply strapping only over edge and/or intermediate cleats for maximum support. Strapping that spans unframed areas is easily broken and may injure cargo handlers. Use stapling to hold banding in place on cleats.
5. Don't overlook lining with adequate waterproof or vaporproof barrier material, where contents are susceptible to wetting damage.

Steel Drums

New steel drums are generally excellent for export. Second-hand drums, unless thoroughly reconditioned and tested, may give trouble because of fatigue caused by dents at the chime and previous damage to the closures. Also consider the following:

1. Closures must be made as prescribed by the manufacturer. Back up friction type covers of drums, as well as cans or pails, with soldering or spot welding at three or more points.
2. Be sure adequate seals are used on locking levers and sealing rings of open end drums. Failure of seals may result in accidental opening of covers.
3. Consider use of tamperproof seals at filling and dispensing holes.
4. Make frequent spot checks of automatic filling machinery by weighing filled drums. Shortages may occur at the source.
5. Do not re-use single or one trip containers.
6. For hazardous materials/dangerous goods, be sure the drums meet DOT/ IMO/ICAO or appropriate standard-making group specifications, and are properly labeled for carriage of the intended cargo.

Fiber Drums

Fiber drums are gaining importance in the export picture. Before using them determine that open storage enroute is not contemplated. Considerations for fiber drums include:

1. High density materials should not be packed into fiber drums.
2. Fiber drums should be filled to the top in order to add rigidity to the package. Use smaller drums if contents are such that weight limits will be exceeded if filled to the top. Avoid empty spaces at the top of the drum.
3. It is advisable to settle or deaerate materials particularly light fluffy powders- during the filling operations. Use of a vibrator or mechanical settler is recommended. Bag-lined drums can be deaerated simply by manually compressing the filled bag.
4. Keep size of drum compatible with weight of contents to avoid overloading.

5. Closures are important. Be sure sealing rings and locking levers are properly in place and will not be accidentally jarred or pulled loose.
6. Handle with mechanical equipment or roll on bottom chimes. Fiber drums are not designed to roll on sidewalk. Avoid cutting, denting and chafing of sidewalls as stacking strength will be lost.
7. If possible, palletize fiber drums to facilitate mechanical handling in warehouses or on docks.

Barrels, Casks or Kegs

The wooden barrel has been a workhorse of overseas trade, dating back to ancient times. Selection of the wrong barrel for your product can result in leakage, contamination, breakage and many other headaches. The following are basic recommendations:

1. Tight (liquid) barrels should be stored bung up. Request stowage on bilges. Slack (dry) barrels should be stored on ends. Never store or ship slack barrels on their sides.
2. Provide reinforcing head cleats running from chime to chime at right angles to headpieces. Cleat thickness should never be greater than chime depth.
3. Use tongue and groove staves with a suitable liner where contents, such as dry chemicals and powders, may sift. Make sure barrel wood and liner material will not contaminate contents.
4. Keep voids in slack barrels to a minimum. Use headliners (strips of coiled elm fastened inside chime) to give barrel heads added strength.
5. Where tight barrels are employed, hoops should be fastened with not less than three fasteners (dogs) per hoop. Provide for inspection at interim transit points, where practicable, to check for leakage. If contents are carried in brine, re-brining at interim points may save contents of leaking units.

Multi-Wall Shipping Sacks

Multi-wall shipping sacks or bags are being used more and more for packaging of powdered, granular and lump materials, particularly dry chemicals. These sacks are flexible containers generally made up from two walls or plies of heavy-duty kraft paper to a maximum of six. Often, they are made in combination with special coatings, laminations, impregnations or even textile material such as bur-lap to give them additional strength and added protection to their contents. Because of the flexibility of these containers, special attention must be given to the use of flexible waterproof or moistureproof barriers in their construction.

There are several types of bags used, the most common being the pasted bottom or sewn bottom open-mouth, and the pasted valve or sewn valve. The pasted bottom and sewn bottom open mouth type bags are closed after filling, by sewing through all plies with a strip of tape incorporated into the sewn end in such a way that it folds over the end to control sifting. They can also be closed by gluing. The valve type bags are closed by manually folding over an external paper sleeve or by the check valve action of an inner paper sleeve when the bags are full. The internal pressure of the contents causes this, and care must be taken that the bags are sufficiently filled to exert this pressure. It must be recognized that slight leakage will nevertheless occur, particularly when the bags are handled.

The use of these bags for overseas shipments should be limited. These bags must be adapted to the requirements of the commodity it contains. This requires careful research and intelligent selection. It is recommended that the loaded bag not exceed 50 pounds. Thought must be given to the value of the product as well as to its hygroscopic properties and chemical and physical characteristics. Utmost consideration must be given to in-transit hazards, such as atmospheric conditions or exposure to the elements, number of transfers and handlings and warehouse facilities. Of major importance is the question as to whether the contents of the sack will be

subjected to contamination if the bags are ruptured or if foreign matter can filter in through stitching holes.

A good practice for the shippers is to include a supply of open mouth refill or overslip sacks with each shipment.

The number of refill sacks should not be less than 1 percent of the number of sacks in the shipment and preferably 3 percent. The refill sacks should be imprinted with instructions for their use as well as identification of the commodity that they will carry. Overslip sacks should be slightly larger than the original sack and constructed of the same number and kind of plies.

Palletizing of a number of sacks, adequately shrink-wrapped and/or banded to the pallet, has been particularly effective in reducing damage and pilferage, and forces use of mechanical handling equipment.

Bales

A well-made bale may be expected to outturn reasonably well in most export trades. Bear in mind, however, that all bales are subject to pilferage, hook holes and water damage. They are, therefore, not recommended for highly valued commodities. To minimize losses, follow these recommendations:

1. Use a primary wrap of fiberboard material where contents may be subject to damage from strapping pressure.
2. Use an inner wrap of creped or pleated waterproof paper. This type of paper is necessary to provide moisture protection and to give with bale distortions without tearing.
3. Provide heavy outer wrap of burlap or similar cloth able to withstand heavy abrasions in transit.
4. Provide "ears" at corners of small bales to facilitate handling without hooks. Bale weights under 100 pounds are less apt to be handled with hooks.
5. A minimum of four flat tension bands should be used. Apply tightly at the maximum bale compression to avoid slipping of end bands.
6. Stencil all shipping and cautionary marks on bale. Do not use tags as these can easily be torn off during normal handling.

Flexible Intermediate Bulk Containers (FIBCs)

These containers, a combination of pack-aging materials and a lifting system, can be used in the transportation of most granular and powder commodities. They should have a capacity not in excess of three cubic meters and/or a gross weight of 3,000 kg and be fitted with integral or detachable devices for lifting/suspension.

FIBCs are manufactured from a fabric or woven polymer, polypropylene, polyethylene, polyester or polyamide; the latter two for use in multi-trip containers where they are expected to encounter arduous conditions. The fabric is made up into a cuboid or cylindrical container stitched with man-made fiber or twine. Some heavy-duty units have welded seams.

Some flexible containers have disposable polyethylene liners that are used to prevent product seepage and improve water-tightness. These liners can also preclude cleaning and extend the life of re-usable containers.

The means of filling are fitted to the top usually in the form of a flexible spout; some types have open tops. Similarly, a discharge fitting such as another spout is located at the bottom of the container. Pro-visions are made to protect the discharge arrangement from dust often by a thimble spout or use of a protective flap.

FIBCs should be inspected prior to each use, checked for abrasions, cuts, contusions, ultraviolet degradation and/or chemical attack evidenced by weakening, softening or discoloration

of the material and damage to coatings. These could lead to possible contamination of contents with unacceptable levels of coating fragments or increased chance of moisture contact.

Additional safe handling points include:

- check for test certificate that indicates the FIBC is an approved type
- ensure the filled FIBC is stable
- close the top inlet correctly
- protect containers from rain and/or pro-longed sunlight
- ensure stability when stacking FIBCs
- secure the containers adequately for transportation

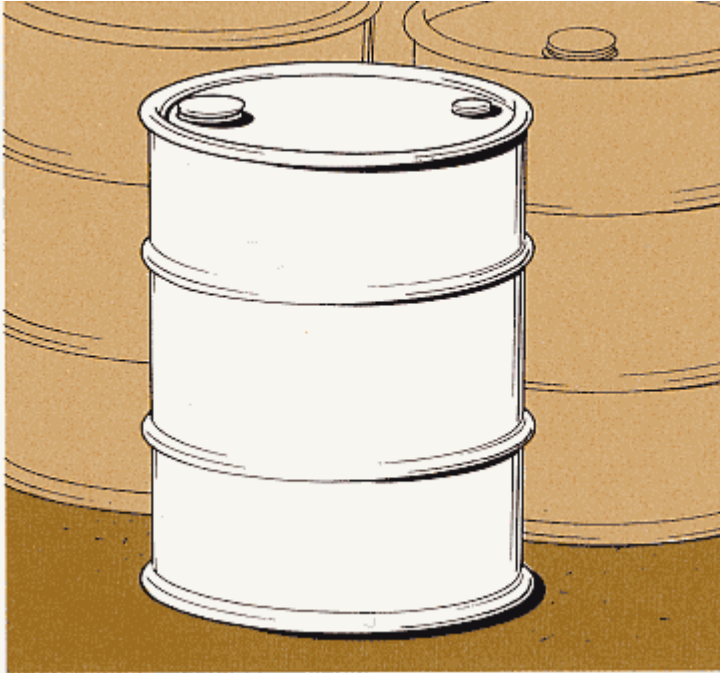

Steel Drums

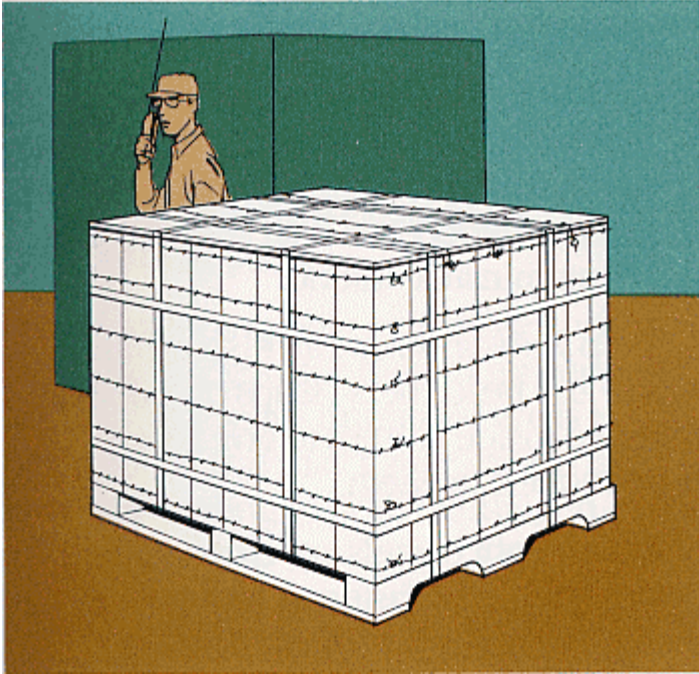

Wirebound Boxes and Crates



Fiber Drums

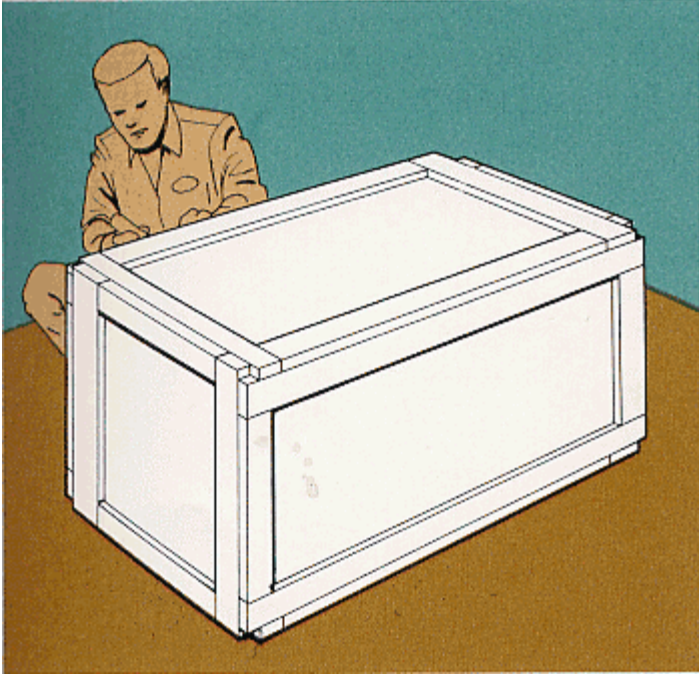

Cleated Plywood Boxes

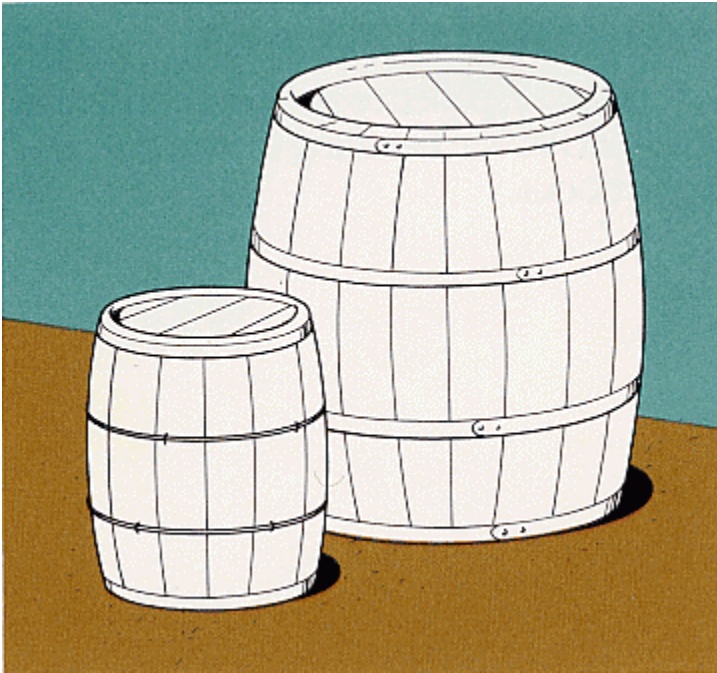

Barrels, Casks or Kegs

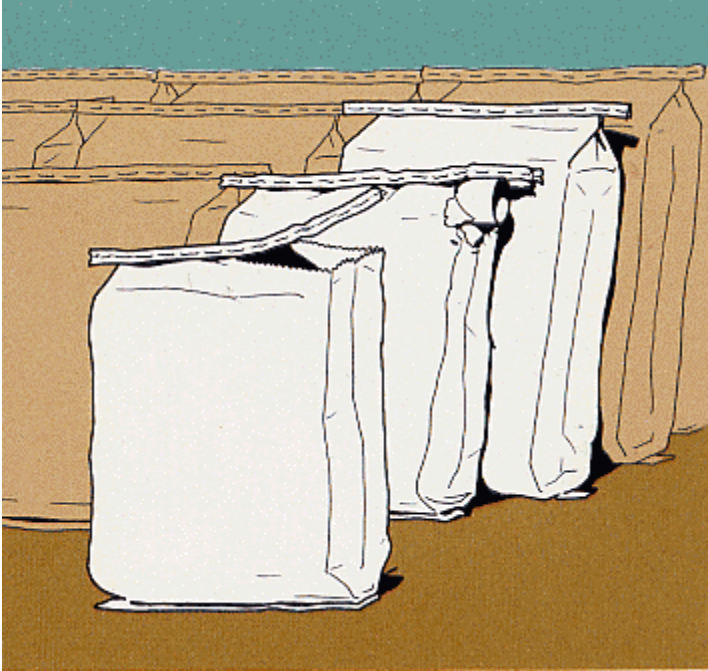

Multi-Wall Shipping Sacks

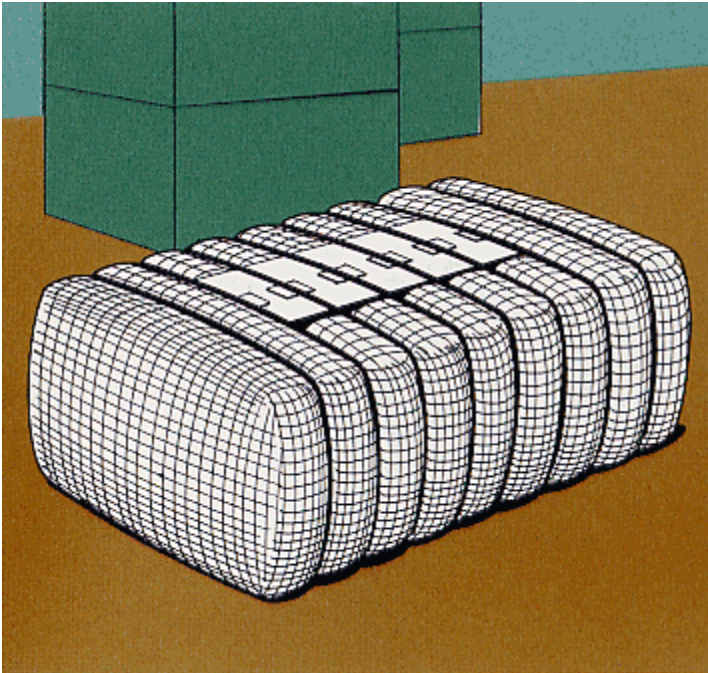

Bales

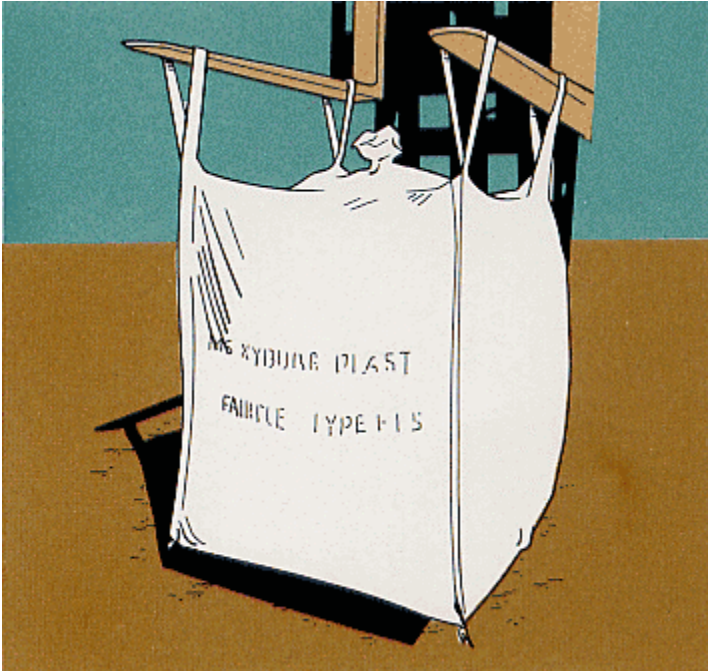

Flexible Intermediate Bulk Containers

Cushioning

Certain types of cargo must be suspended or protected against shock and vibration by a cushion that gradually increases resistance against item movement.

Selection of the correct cushioning material depends on the item's fragility, measured in "Gs" or the maximum deceleration it can withstand without damage, overall dimensions, weight, shape, surface finish and built-in shock resistance. Other considerations include anticipated drop heights based on handling and transportation environment. Many cushioning material suppliers provide performance data with their products.

Cushioning Materials and Characteristics

Cushioning Characteristics (1)

Type Material	Abrasion Resistance	Resilience	Compression	Absorption	Water Resistance	Dusting(2)	Damping Quality(3)	
Expandable Polystyrene (EPS)	Good	Medium	High	Low	High	Low	Low	
Cellulosic	Good	Medium	High	(4)	(4)	High	Excellent	
Wood Excelsior	Poor	Medium	High	High	(4)	High	Good	
Hair Felt	(5)	Medium	Low	(5)	(5)	Low	Poor	
Solid/ Corrugated Fiberboard	Poor	Medium	Low	Low	High	High	Poor	
Wax Shredded Paper	Poor	Low	High	High	Low	High	Excellent	
Cellular, Plasticized, Polyvinyl Chloride	(4)	High	Low	Nil	High	Low	Good	
Polyurethane (Fab or Molded)	Good	(8)	(8)	(8)	Low	Low	(8)	
Polyurethane Foam (6)	Good	(6)	(6)	(6)	Low	Nil	(6)	
Polyethylene Foam (7)	Fair	High	High	High	High	Low	Good	
Latex Foam Sponge Rubber	Good	High	Low	High	Low	Low	Fair	
Paper Honeycomb			Energy dissipating medium only					

- (1) These ratings are general in nature. Any characteristics can be varied in a customized mode.
- (2) Dusting describes the extent of material breakdown in small or dustlike particles in transit.
- (3) Damping quality reflects the ability of the material to progressively diminish vibrations or oscillation.
- (4) This material is manufactured under different specifications that vary the degree of named characteristics but generally is susceptible to moisture.
- (5) Used mainly as padding for large and heavy items. Often glued in place.
- (6) This is a foam-in-place material that can vary in make-up to meet requirements.
- (7) This material is available with anti-static and/or fire retardant additives.
- (8) This material can be manufactured to varying specifications to meet shipment needs.

UNIT LOADS

Many commodities can be economically palletized or unitized to facilitate their handling, stowage and protection. Often, packing costs can also be significantly reduced. Pallet and unit loads offer the following additional advantages:

- Requires use of mechanical handling equipment and reduces the manual handling damage hazard since it eliminates the multiple handling of individual items.
- Reduces opportunity for pilferage and theft and permits early detection of tampering.
- Speeds loading and unloading of trailers, boxcars, intermodal containers, barges, ships and aircraft.
- Facilitates application of water-proofing protection to the load: the overwrap applied accompanies the load for the entire journey.
- Reduces incidence of lost or astray items.
- Facilitates checking and inventory of shipment.

PALLETIZING is the assembly of one or more packages on a pallet base and securing the load to the pallet.

PALLETIZING CARGO

The optimal size of the pallet depends on the internal dimensions of the intermodal container and the form and weight of the packages. Four-way pallets (i.e., those that can be lifted from all sides by a forklift truck), usually make best use of the floor area of a container.

The recommended packing patterns for standard pallet sizes are shown in the following charts.

Select the pallet that:

1. Best utilizes the space of the mode of transportation to be used.
2. Best utilizes the package dimensions of the item to be shipped.
3. Limits the weight of the palletized load to 2,200 pounds (1,000 kg).

The following images show standard methods of transporting cargo across rivers in North America in the early 19th century

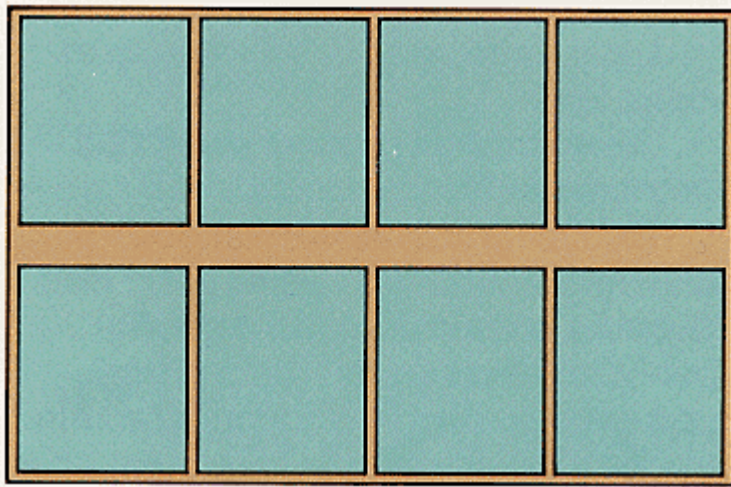

Storage pattern A for pallets.

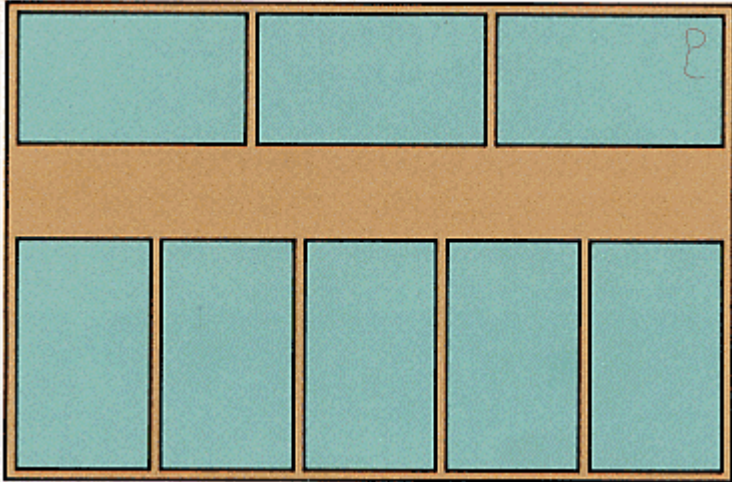

Storage pattern B for pallets.

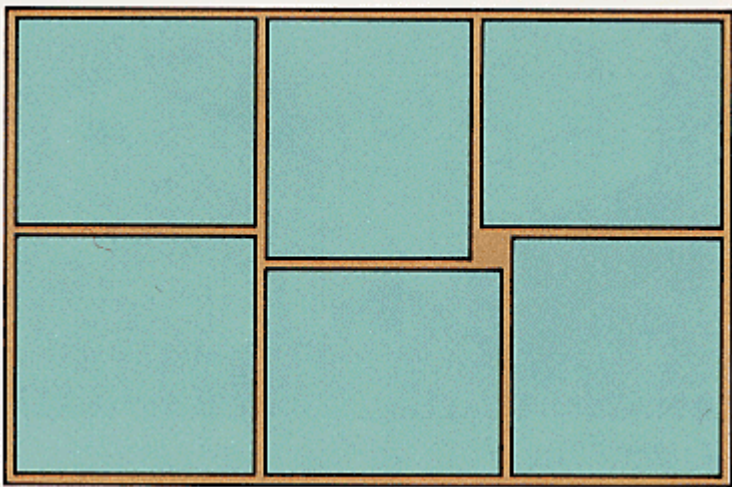

Storage pattern C for 4-way pallets only.

Container Stowage

Size of Container	20'			40'		
Pallet size	Recom- mended pattern	Max. no.	Floor utili- zation %	Recom- mended pattern	Max. no.	Floor utili- zation %
<i>mm inches</i>						
1,000 x 800 40" x 32"	A	14	83.2	A	28	81.2
1,100 x 800 44" x 32"	A	14	91.4	A	28	89.3
1,100 x 900 44" x 36"	A	12	88.1	A	26	93.3
1,100 x 1,100 44" x 44"	A	10	99.7	A	20	87.7
1,100 x 1,400 44" x 55"	A	8	91.3	A	16	89.3
1,200 x 800 48" x 32"	B/C	11	78.4	B/C	23	80.1
1,200 x 1,000 48" x 40"	C	10	89.0	B/C	20	87.0

Assemble the individual unit packages on the pallet base without an overhang. Vertically aligned packages provide maximum stacking strength; however, inter-locking patterns afford maximum stability. The load pattern should minimize voids.

Insert spacers between the rows or layers of irregularly shaped items.

Adhesives can be used between cartons in a uniform load.

Secure the load tightly and firmly by using horizontal and vertical strapping.

Plastic shrink wrap can be used to stabilize palletized loads and also affords some protection against wetting. Another method used for protecting cargo susceptible to water damage is overwrapping with a barrier material.

Provide stacking protection to the top of the pallet by using a lumber, plywood or fiberboard cap. Loads that are subject to compression damage must also be supported with vertical framing.

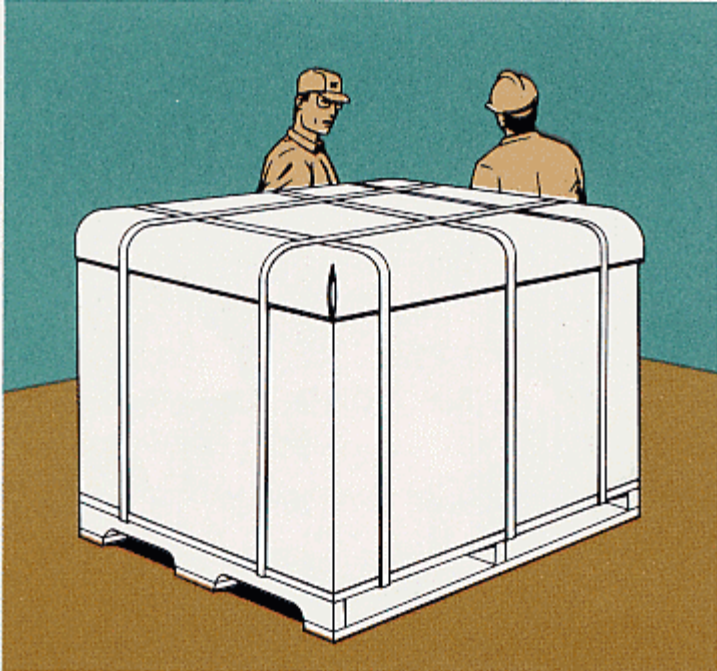

Palletized Consolidation Container



Palletized Load of Bagged Cargo

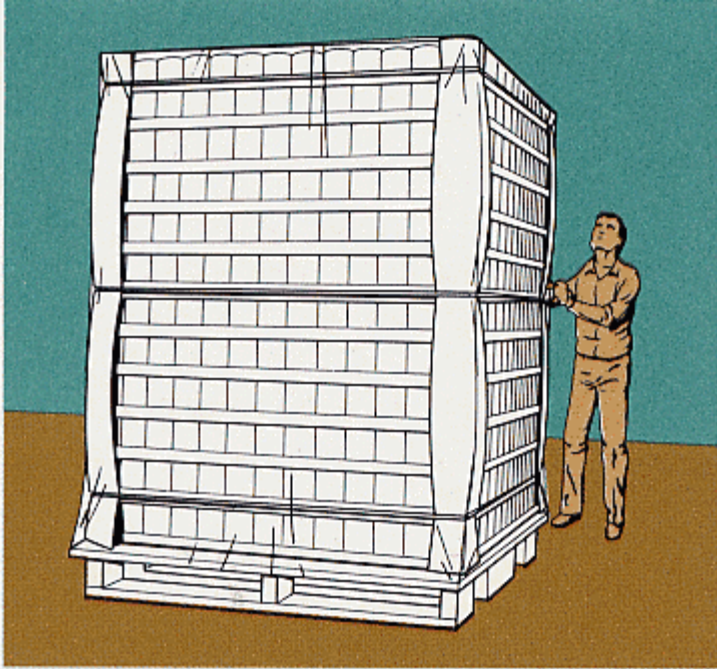

Shrink Film Overwrap of Palletized Load

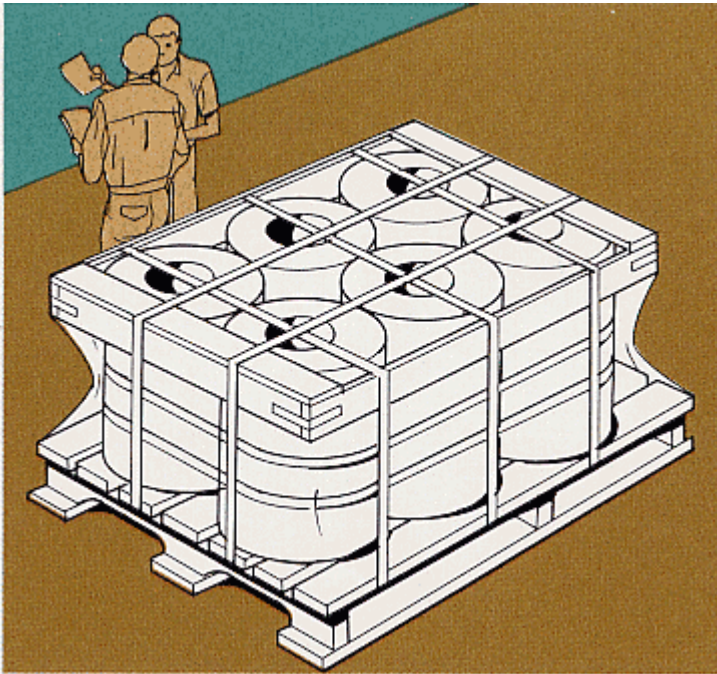

Palletized Drum Load

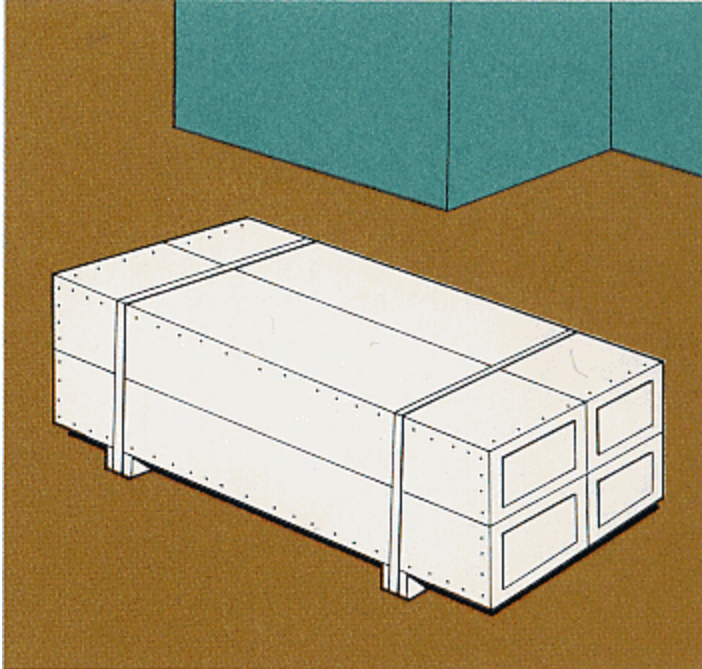

Unitized Load

UNITIZING CARGO

Unitizing is the assembly of one or more items into a compact load, secured together and provided with skids and cleats for ease of handling.

Assemble individual items into one unit by bolting, nailing or strapping together.

Provide vertical cleats on sides of load to facilitate handling by cargo slings.

Provide water damage protection by using plastic shrink wrap or stretch wrap on individual items before assembly into unit load.

Apply shrink wrap or stretch wrap to entire load.

Use waterproof paper or plastic film overwrap.

The American National Standards Institute (ANSI) publishes a guide to aid manufacturers, consumers and the general public in selecting unit-load and transport-package sizes to efficiently fit within truck trailers, intermodal containers, or railroad box-cars. Unit load stacking patterns are also presented.

ANSI can be contacted at:

1430 Broadway
New York, NY 10018
Reference ANSI MH10

Security

Cargo security worldwide must be improved if theft and related losses are to be reduced. Losses range from the pilferage of individual items of cargo to the theft of a 40-foot container or the hijack of a tractor/trailer. Although the latter can-not be ignored, the majority of incidents involve cargo taken from transportation facilities by personnel authorized to be there and on vehicles controlled or similarly authorized by management. There is also a growing sense of the vulnerability of ship and ports/harbors to criminal and terrorist violence.

The task at hand is to establish and maintain a cargo security program, providing organizational, physical and procedural standards.

The Department of Transportation handbook entitled Guidelines for the Physical Security of Cargo, revised and up-dated by the National Cargo Security Council, is intended to assist responsible management within the entire transportation network. Clearly not regulatory in nature,

the Guidelines, nonetheless, reflect latest state-of-the-art technologies and are strongly encouraged and suggested by prudence. An effective cargo security system can be modeled upon them. Copies of this publication are available through the Council's office.

In some cases, attaining and implementing these recommended practices may entail substantial expense. However, they have proven to be effective. Conversely, "bargain basement" measures may provide a false sense of security and an open invitation to theft/pilferage. Experience demonstrates that the decrease in cargo loss, i.e., loss of profit dollars, far outweighs the expense of taking recommended security measures.

Several other organizations have pledged their support to making the ports of the world safe and secure. They are positioned to offer "local" solutions/ approaches.

- The Port Security Committee of the American Association of Port Authorities is attempting to combat cargo theft by initiating discussions between transportation entities, insurance carriers, port management and law enforcement on the present state of affairs in cargo security. It has been concluded that cargo theft can be controlled effectively only when all concerned parties communicate with each other, and understand that cargo theft damages the profit potential, prestige and credibility of everyone within the industry.
- The International Association of Chiefs of Police is also strongly committed to the cargo crime battle. The Cargo Security committee of this association has provided training seminars and other aids to law enforcement and industry personnel involved in cargo security. They have assisted in the development of specialized training courses through the United States Federal Law Enforcement Training Center at Glynco, Georgia.
- On the global scene, the International Association of Airport and Seaport Police has addressed the problem by developing a truly international team of port law enforcement managers and directors capable of coordinating cargo theft investigations around the world. The IAASP is also committed to assisting the United Nations on the world's cargo security situation, and has offered its services, expertise and other resources to help all nations deal with the problem.

Additional information relative to the aforementioned services and capabilities can be made by writing to the following addresses:

ATTN: National Cargo Security Council
1945 Old Gallows Road
Suite 580
Vienna, VA 22182

ATTN: Port Security Committee
American Association of
Port Authorities
1010 Duke Street
Alexandria, VA 22314

ATTN: Cargo Security Committee
International Association of
Chiefs of Police
1110 Glebe Road
Arlington, VA 22201

ATTN: General Secretariat
International Association of Airport and Seaport Police
580-2755 Lougheed Highway
Port Coquitlam
British Columbia
Canada V3B5Y9

Although the pattern of maritime fraud, including insurance fraud, documentary fraud and charter party defaults, continues to decrease, significant opportunities still exist due to prevailing economic and political conditions. "Fraudsters" continue to exploit embargoes and countries where increasing trade activity is not matched with improvements in local infrastructures.

The International Chamber of Commerce's International Maritime Bureau (1MB) continues to work toward the prevention and control of fraud and related suspect practices. They can be reached at:

Maritime House
1 Linton Road
Barking, Essex 1G11 8HG
United Kingdom
44-81-591-3000 (Phone)
44-81-594-2833 (FAX)
Telex: 89564921MB LDNG

Note: Systems that integrate a powerful x-ray source with a vapor detection device now enable Customs or relevant port authority personnel to quickly examine cargo without the need to unload and un-pack conveyance, container or pallet. Shippers should be advised that the high energy x-ray capable of penetrating fully loaded ISO containers can adversely affect goods, inter alia, live tissue, unexposed photographic material, certain raw materials for the manufacture of film and some pharmaceuticals. In these instances, manifests should be declared as to contents and bills of lading clausued "DO NOT X-RAY" Having the local representative or consignee attend during clearance operations is a further positive step.

Suggestions for Valuable Shipments (Air)

In planning the shipment of valuable cargo, seek a level of security comparable to the security you know you require for your own premises.

- Select a tariff designed for the movement of valuable goods and abide by its recommendations.

- Make advance booking with a carrier for shipment so consignees may be on alert for arrival.

- Tender shipment to carrier not more than 3 hours prior to the scheduled departure of the flight for which advance arrangements have been made.

- Notify the consignee to accept delivery of the shipment at destination within 3 hours after scheduled arrival time of flight.

 - Avoid shipping when consignment will arrive at destination on weekends or holidays.

 - When delays in acceptance of valuable merchandise are anticipated e.g., when weekend or holiday arrivals are unavoidable, arrange for special handling such as transportation via an armored vehicle or placement in a suitable repository.

 - Adhere to minimum package dimensions. Most tariffs provide for minimum package size of one cubic foot.

 - Use only new, well-constructed packaging for your product.

 - Clear and complete delivery and handling instructions should appear on at least three surfaces of the exterior shipping package.

 - Eliminate all product identification on the exterior of shipping package.

 - Avoid shipping on a routine schedule and report suspected theft quickly.

MARKS AND SYMBOLS

MARKS

The primary purpose of marking is the identification of the shipment, enabling the carrier to forward it to the ultimate consignee. Old marks, advertising and other extraneous information only serve to confuse this primary function for cargo handlers and carriers. Follow these fundamental marking rules:

1. Unless local regulations prohibit, use coded marks; particularly where goods are susceptible to pilferage. Change them periodically to avoid familiarity by cargo handlers. Trade names should be avoided as they may indicate the nature of the contents.
2. Consignee (identification) marks and port marks showing destination and transfer points should be large, clear and applied by stencil with waterproof ink. They should be applied on three faces of the package, preferably side, and/or ends and top.
3. If commodities require special handling or stowage, the shipping package should be so marked, and this information should also appear on the bill of lading.
4. Cautionary and handling markings must be permanent and easy to read (use the languages of both the origin and destination countries). The use of stencils is recommended for legibility—do not use crayon, tags, or cards. An example of marking on an export pack is illustrated.

NON-HAZARDOUS PICTORIAL MARKINGS

It is recommended that handling instructions be printed on the exterior pack in the language of the destination country. It is not unusual for a shipment to be handled by another country along the transport path or by cargo handlers that cannot read. These potential problems can best be overcome by pictorial markings. The international symbols depicted represent markings that have been accepted as standards.

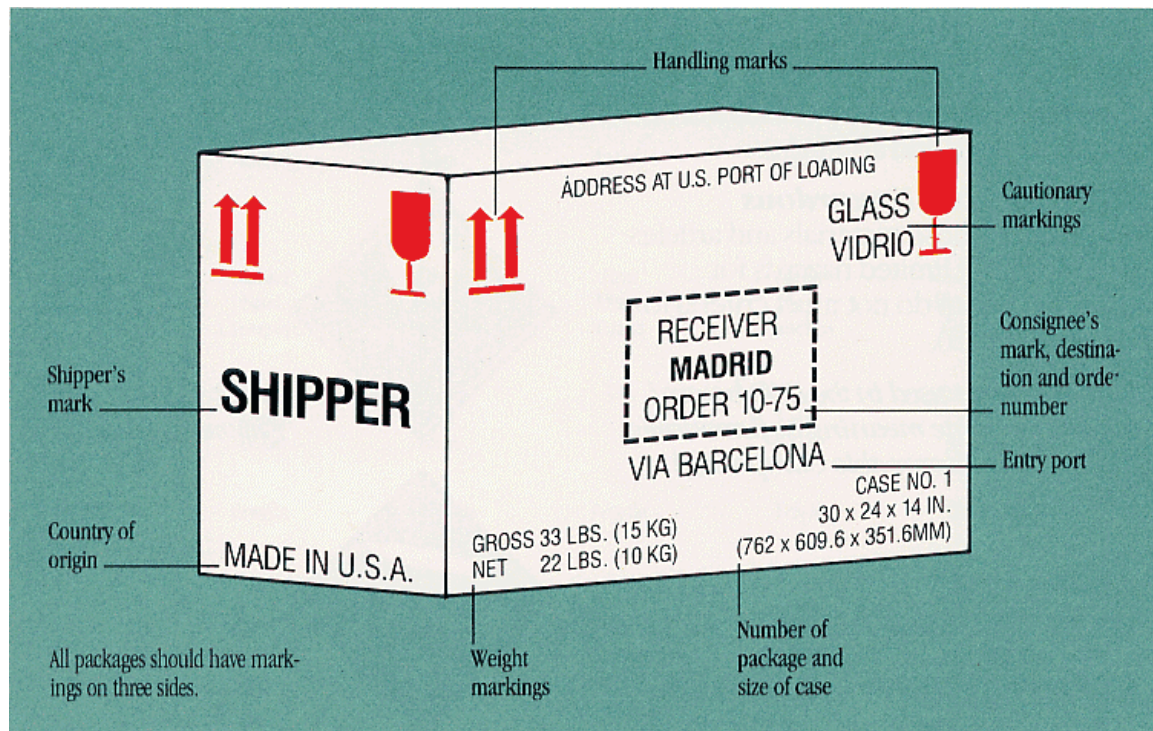

HAZARDOUS MATERIALS

Unilateral state regulation of international commerce is impractical in today's inter-dependent world. Procedures that are acceptable in one country and forsaken in another inhibit world trade through embargo or unacceptable delay in cargo reaching its ultimate destination. The labels shown on these pages are the hazardous material (dangerous goods) identification adopted by all IMO and ICAO member countries to smooth the flow of these type materials in waterborne and air commerce. The color coding, symbol and class number (when displayed) are universal.

These labels provide an important identification of packaged dangerous goods in transport. They will alert cargo handlers to special stowage and segregation needs along the

transport path. Dangerous goods regulations almost always require special documentation and packing under strict criteria. These shipments should be booked in advance with the carrier so that applicable restrictions can be determined prior to actual shipment.

IMPORTANT—Do not assume that compliance with domestic regulations will automatically qualify a shipment for passage through enroute countries and the destination port. Requirements that are not met can easily be the difference between profit and loss.

If the material may be hazardous, then, in addition to all known required markings and labels, furnish pertinent chemical or physical data.

All international air and ocean shipments must meet UN performance packaging standards, effective January 1991. There are, however, some exceptions such as limited quantity shipments.

Shippers will be permitted to continue to use the Code of Federal Regulations (CFR), Title 49 for all domestic shipments. However, the new ICAO Regulations are MANDATORY for all international shipments originating, terminating or in transit through the United States.

Hazard Classes

1. **Explosive** -(Class 1.1,1.2,1.3,1.4,1.5 and 1.6). Articles bearing Explosives labels shown and falling in Divisions 1.1,1.2,1.3 (with a few exceptions), 1.4F and 1.5 are normally forbidden for air transport.

2. **Gases** -(non-flammable, flammable* and toxic).

3. **Flammable Liquids**.

4. **flammable Solids, Spontaneously Combustible Substances and Water Reactive ("Dangerous when wet") Substances**.

5. **Oxidizing Materials** -(oxidizing matter and/or organic peroxides).

6. **Poisonous Substances** (liquids and solids) **and Infectious Substances**.

7. **Radioactive Materials** -(White I, Yellow II or Yellow III).

8. **Corrosive Materials** -(acids, corrosive liquids/solids and alkalines).

9. **Miscellaneous Hazardous Materials** -(those materials and articles that may present limited hazards for transportation but do not meet criteria for Class 1 through 8).

* Inflammable as used in the IMO hazard labels has the same meaning as flammable. IMO uses Non-Flammable Compressed Gas wording

Note:

(A) Except for Radioactive and Handling Labels, text indicating the nature of risk on the label is optional.

(B) When secondary or tertiary hazards are present, the appropriate label must be used. The omission of the hazard class or division number indicates the risk is subsidiary.



*Class 1
Explosives*



*Class 3
Flammable Liquid*



*Class 1
Explosives*



*Classes 4.1
Flammable Solid*



*Class 1
Explosives*



*Class 4.2
Spontaneously Combustible
Substances*



*Class 2.1
Flammable Gases*



*Class 4.3
Water Reactive
Substances*



*Class 2.2
Non-Flammable Gases*



*Class 5.1
Oxidizing Agent*



*Class 2.3
Poisonous Gases*



*Class 5.2
Organic Peroxide*



*Class 6.1
Poisons (Toxicity
Groups I and II)*



*Class 8
Corrosive Materials*



*Class 6.1
Poisonous Substances
(Toxicity Group III only)*

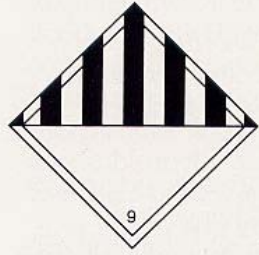

*Class 9
Miscellaneous
Hazardous Materials*



*Class 6.2
Infectious Substance*



*Handling Label
(For Air Shipments Only)*



*Class 7
Radioactive Materials
(White I)*



*Handling Label
(For Air Shipments Only)*



*Class 7
Radioactive Materials
(Yellow II)*



*Class 7
Radioactive Materials
(Yellow III)*



FRAGILE



HANDLE WITH CARE



KEEP DRY



PROTECT FROM HEAT



USE NO HOOKS



SLING HERE SLING HERE



LIFT CART HERE



DO NOT STACK



DO NOT ROLL



DO NOT TUMBLE

FOTO

PHOTOGRAPHIC MATERIALS



PERISHABLE



KEEP FROZEN



CLAMP HERE



DO NOT FREEZE



CENTER OF GRAVITY

LIVE ANIMALS



CONTENTS
ABC AIR LINES

Cautionary Markings (refer to previous images)

Cautionary Markings

English	French	German	Italian	Spanish	Portuguese	Swedish	Japanese	Chinese	Arabic
Handle with Care	Attention	Vorsicht	Manneggiare con Cura	Manéjese con Cuidado	Tratar Con Cuidado	Versamt	取扱注意	小心處理	بانتباه
Glass	Verre	Glas	Vetro	Vidrio	Vidro	Glas	ガラス	玻璃製品	زجاج
Use No Hooks	Manier Sans Crampons	Ohne Haken handhaben	Non Usare Ganci	No Se Usen Ganchos	Nao Empregue Grachos	Begagna inga kroka	手鉤無用	勿用鈎士	عدم استعمال خناطيف
This Side Up	Cette Face En Haut	Diese Seite oben	Alto	Este Labo Arriba	Este Lado Para Encima	Denna sida upp	天地無用	此面向上	هذه الجهة فوق
Fragile	Fragile	Zerbrechlich	Fragile	Frágil	Fragil	Omtaligt	毀物注意	易碎貨物	قابل للكسر
Keep In Cool Place	Garder En Lieu Frais	Kuehl aufbewahren	Conservare in luogo fresco	Manténgase En Lugar Fresco	Deve Ser Guardado Em Lugar Fresco	Forvaras kallt	冷暗貯蔵	保持低温	احفظ بمكان بارد
Keep Dry	Proteger Contre Humidité	Vor Naesse schuetzen	Preservare dall umidita	Manténgase Seco	Nao Deve Ser Molhado	Forvaras torrt	水気厳禁	保持乾燥	احفظ بمكان جاف
Open Here	Ouvrir Ici	Hier öffnen	Lato da Aprire	Abrase Aqui	Abra Aqui	Oppnas har	取出口	由此開啟	افتح هنا

TABLES AND GUIDES

Export Guide

Cargo moves on paper! The part you play is shown in the/allowing steps.

Shipper

1. Prepares Domestic Bill of Lading for movement of cargo to pier, and sends copy to his forwarder along with packing list.
2. Marks cargo plainly to show:
 - special shipping and handling instructions
 - gross and net weights
 - destination
 - country of origin

3. Checks Ocean/Air Bill of Lading:

- number of packages/weight
- marks and numbers
- description of cargo
- destination
- gross weights of each package shipped
- consignee

Inland Carrier

4. Accepts cargo for transit to the port/ airport.
5. Secures container interchange agreement.
6. Advises freight forwarder or shipper's local representative of cargo arrival.
7. Obtains Receipt from forwarder or other representative to accompany cargo.
8. Contacts terminal operator to make appointment for special handling or equipment, if required.

Forwarder

9. Provides Dock Receipt and special permits, if any, to delivering inland carrier.
10. Checks Dock Receipt for completeness:
 - name of shipper
 - name of vessel/airline
 - ports of loading and discharge
 - description of cargo
 - shipper's export declaration number, if required

Terminal Operator

11. Issues pass to driver at gate house.
12. Assigns driver a checker and an unloading spot.
13. Retains original of dock receipt and forwards a copy to the Ocean Carrier/Airline.

Airline/Ocean Carrier

14. Issues Bill of Lading to shipper or shipper's agent.

Import Guide

Ocean Carrier/Airline

1. Notifies consignee on arrival of shipment.
2. Provides freight release to terminal operator.

Customs Broker

3. Obtains customs release, freight release, clearances and other required documents before contacting inland carrier.
4. Forwards to inland carrier an original of the Domestic Bill of Lading and an original Delivery Order, which authorizes pickup of cargo.
5. Checks Bill of Lading for completeness.
6. Checks Delivery Order for completeness:
 - forwarder's name
 - shipper's name
 - ultimate consignee's name
 - inland carrier making pickup
 - vessel/airline
 - arrival date
 - voyage/flight number
 - ocean/air bill of lading
 - pier/air cargo terminal number and location
 - marks and numbers
 - number of packages
 - description of goods
 - gross weights
 - legible signatures
7. Guarantees with terminal operator loading charges and demurrage.

Terminal Operator

8. Issues pass to driver at gatehouse.

9. Checks Delivery Order for completeness and legibility.
10. Assigns checker and loading spot.
11. Loads cargo. Checker notes exceptions and shortages.

Inland Carrier

12. Secures container interchange agreement.
13. Ascertains expiration of free time and availability of cargo for pickup.
14. Provides driver with original and copy of Delivery Order.
15. Contacts terminal operator to make appointment, if required.
16. Dispatches trucker to the terminal.
17. Signs tally and loading ticket. Exceptions and shortages noted.
18. Advises broker of completion of cargo pickup.

Consignee

19. Upon receipt of shipment, checks quantity and condition against documentation.
20. If loss or damage is discovered, makes appropriate notation on delivery receipt. Follows recommendations contained in the "How to File a Cargo Claim" section.

Export Documents

1. Bill of Lading

A receipt for the cargo and a contract for transportation between a shipper and the carrier. It may also be used as an instrument of ownership.

2. Dock Receipt

Used to transfer accountability for the cargo between domestic and international carriers at the terminal.

3. Delivery Instructions

Provides specific information to the inland carrier concerning the arrangement made by the forwarder to deliver the cargo.

4. Export Declaration

Required by the U.S. Department of Commerce to control exports and acts as a source document for export statistics.

5. Letter of Credit

A financial document issued by a bank at the request of the consignee guaranteeing payment to the shipper for cargo if certain terms and conditions are fulfilled.

6. Commercial Invoice

A bill for the goods from the seller to the buyer. It is often used by governments to determine the true value of goods for the assessment of customs duties.

7. Certificate of Origin

A document that is used to assure for the buying country precisely in which country the goods were produced.

8. Insurance Certificate

Assures the consignee that insurance is provided to cover loss or damage to the cargo while in transit.

9. Transmittal Letter

A list of the particulars of the shipment and a record of the documents being transmitted together with instructions for disposition of documents.

Import Documents

1. Arrival Notice

Sent by the carrier, it informs the "notify party" of the estimated arrival date of the shipment.

2. Customs Entry

Required by U.S. Customs for entering goods into the United States. The form contains information as to the origin of the cargo, a description of the merchandise and estimated duties applicable to the particular commodity. Estimated duties must be paid when the entry is filed. Associated documents include:

- Entry Summary (for certain "trade sensitive" imports).
- Delivery Authorized Document (DAD) —A form prepared by the Customs broker, and lodged with the carrier as evidence of Customs release.
- Immediate Transportation (IT) Entry-Allows the cargo to be moved to an inland destination via a bonded carrier.
- Transportation and Exportation Entry-Allows goods to enter the U.S. for the purpose of transshipment to a third country.

3. Carriers Certificate and Release Order

Used to advise Customs of the details of the shipment, its ownership and port of loading.

4. Delivery Order

Issued by the consignee or consignee's Customs broker to the carrier as authority to release the cargo to the inland carrier.

5. Freight Release

Evidence that the freight charges for the cargo have been paid.

Foreign Trade Contracts

As we have tried to demonstrate, shipping goods internationally can be risky. Aside from physical loss or damage, cargo delivery may not take place due to other reasons, and erodes the climate of confidence between the buyer and seller. However, if when drawing up their contracts, the parties can agree on terms of sale, they have gone a long way toward delineating respective responsibilities and precluding misunderstandings and subsequent formal disputes.

The International Chamber of Commerce publishes their Incoterms to provide a set of international rules for the interpretation of the terms commonly used in foreign trade transactions for those who prefer the certainty of uniformity over the varied interpretations of different countries and jurisdictions. Another source is the National Foreign Trade Council's Revised American Trade Definitions.

Typical Transactions

<u>Terms of Sale</u>	<u>International Code</u>	<u>Risk Transfer Point (Seller to Buyer)</u>
Ex Works (Factory/Warehouse/etc.)	EXW	Seller's Factory, Warehouse, etc.
Free Carrier (named point)	FCA	Depot, Country of Origin
Free Alongside Ship	FAS	Upon Effective Delivery Alongside Vessel
Free On Board (named port of shipment)	FOB	On Board Vessel, Port of Shipment
Cost and Freight (C&F)	CFR	On Board Vessel, Port of Shipment
Cost, Insurance and Freight	CIF	On Board Vessel, Port of Shipment
Delivered at Frontier	DAF	At named point at frontier but before Customs Border of adjoining country
Delivered Ex Quay (Duty Paid)	DEQ	On Quay/wharf, Port of Destination
Delivered Ex Ship	DES	On Board Vessel, Port of Destination